

Service valve

Post-meter valve with hand wheel and drainage plug

Construction characteristics

- Resilient seated gate valve with smooth straight through bore with internal threads on both sides
- The bonnet seal lies housed between the body and bonnet
- The drain plug has a G 1/4" thread and is closed with brass plug and seal
- All surfaces in contact with drinking water correspond to hygiene requirements acc. to ÖNORM B 5014/Part 1 (KTW guidelines); the valve round plug is drained; there is no valve bag, the internal surfaces allow no deposits

No. KR353



Material | Technical features

1/2 **Body (1), bonnet (2)**

DN 20 - DN 25 made of forged brass

3 **Valve round plug** made of brass, with vulcanised elastomer

4 **Stainless steel spindle** with rolled thread guided in brass
O-ring bush and triple sealed with O-rings

5 **O-rings** made of elastomer

6 **O-ring bush** made of brass

7 **Hand wheel** made of plastic (optional aluminium)



Suitable accessories

Installation bracket: No. KR331

Order no.	Version	MOP (PN)	Dimensions / DN	
			3/4"	1"
KR353	internal thread on both sides	16		

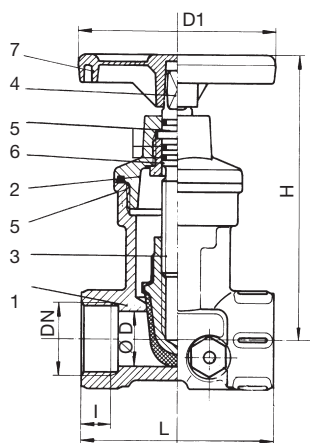

DN	Valve				Weight
	L	H	D1	I	
3/4"	90	125	90	12	1,65
1"				14	