

E3 Valve - BAIO Socket-Spigot



For ductile iron, steel, PE and PVC pipes,
DN 80 – 300, PN 16

Design features

- Resilient seated gate valve with smooth straight-through bore
- One side with spigot and with one side socket for ductile iron pipes
- One extension spindle for several dimensions
- Suitable for operation by automatic actuators
- Suitable for cleaning with a cleaning pig
- Easy retrofitting of position indicator and automatic actuators on the standard bonnet

No. NL00E3

Standard version: without handwheel and extension spindle without gaskets



Suitable accessories

Suitable accessories: see page G 1/2

Handwheel:		No. 7800
Extension spindles:	rigid	No. 9000E2/E3
	telescopic	No. 9500E2/E3
Surface boxes:	rigid	No. 1750
	telescopic	No. 2050, No. 2051K
Restraint clamp:	Hawle stop	No. NL80, NL78 NL82, NL84
	BAIO lip seal (BLD):	for DCI pipes No. NL85
GKS pipe seal:	for PE/PVC pipes	No. NL86
Actuator:		No. 9920
Adapter for actuator (E2/E3 adapter):		No. 8630E2/E3
Base plate:	No. 3481, No. 3482	
Sealing cap:	No. 2156, No. 2157	
Spindle extension:	No. 7820, No. 7825	
Position indicator:	No. 2170E2/E3	
HAWAK pillar:	No. 9894, No. 9895	

Order no.	Version	MOP (PN)	Dimensions/DN							
			80	100	125	150	200	250	300	
NL00E2	Socket-spigot	16								

E3 Valve - BA10 Socket-Spigot

For ductile iron, steel, PE and PVC pipes, DN 80 – 300, PN 16

No. NL00E3

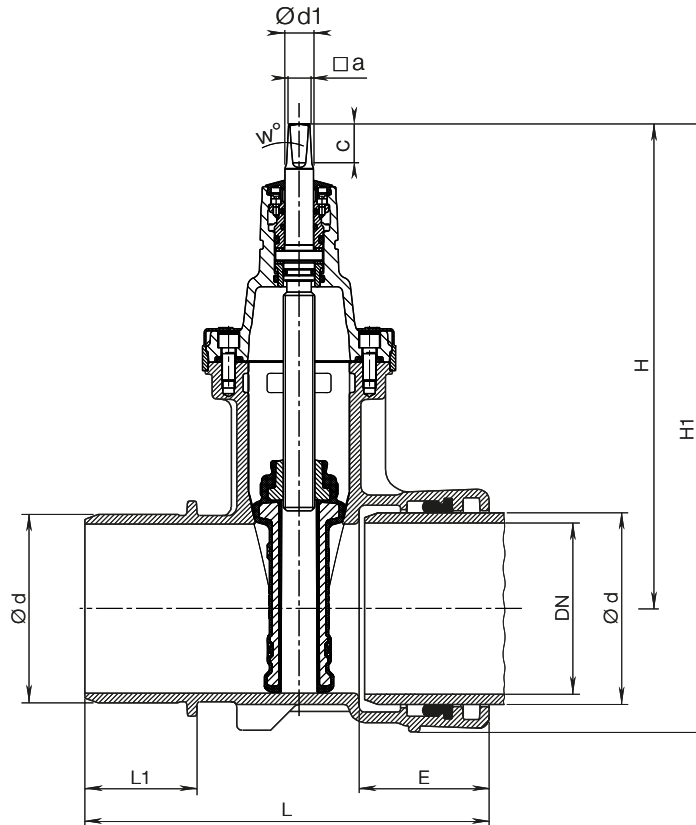

DN	Ød	Valve					Spindle				Weight
		L	L1	E	H	H1	□ a	c	w°	Ød1	
80	98	295	82	110	313	433	17,3	35	3°	24	16,0
100	118	320	102	105	343	475	19,3	38		24	21,3
125	144	350	109	115	421	566	19,3	38		26	34,5
150	170	360	109	115	433	595	19,3	38		26	37,5
200	222	390	115	125	541	735	24,3	48		30	59,5
250	274	536	164	174	670	874	27,3	48		36	104,0
300	326	599	177	198	731	986	27,3	48		36	155,0