

Freeflow below ground hydrant

“height adjustable” PN 16

Design features

- Height adjustable
- Completely free passage
- With flange or BAIO spigot
- Heavy corrosion protection by epoxy coating and non-corroding materials
- Tried and tested, not sensitive to dirt
Plug disk shut-off with fixed stops
- Automatic drainage system with pressure control, drain time less than 10 min.
- Minimal torque for operation
- Maintenance free
- Flange sized and drilled according to EN 1092-2 | PN 16

Suitable accessories

- Suitable accessories:** see page H 1/2
- Drainage element No. 5062
 - Flanged duck foot bend No. 5045, No. 5046, No. 5049
 - Operating key No. 3460, No. 3461
 - Flat gasket No. 3390
 - Bolts No. 8810, No. 8830, No. 8840
 - Surface boxes No. 1950, No. 1950E, No. 1950K
 - Dirt and anti-twist protection No. NL92

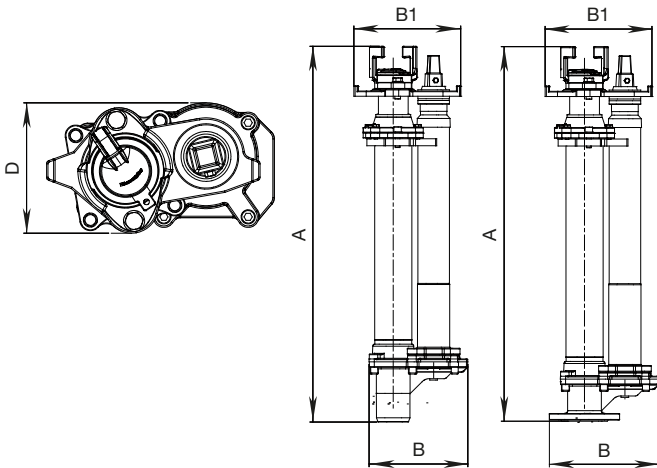

Freeflow below ground hydrant “height adjustable”

No. 5070

No. 5071



Order no.	Version	MOP (PN)	Pipe cover			
			1,00 – 1,30 m	1,25 – 1,55 m	1,50 – 2,05 m	2,00 – 2,55 m
5070	Flange connection DN 80	16				
5071	BAIO spigot connection DN 80					

Flange connection DN 100 on request

Order no.	MOP (PN)	Pipe cover	Connection	A	B	B1	D	Weight
				min – max				
5070	16	1,00 – 1,30 m	Flange DN 80	740 – 1040	280	305	190	40,0
		1,25 – 1,55 m		990 – 1290				52,0
		1,50 – 2,05 m		1240 – 1740				58,0
		2,00 – 2,55 m		1740 – 2290				75,0
5071	16	1,00 – 1,30 m	BAIO spigot DN 80	805 – 1105	280	305	190	38,0
		1,25 – 1,55 m		1065 – 1365				43,0
		1,50 – 2,05 m		1315 – 1865				48,0
		2,00 – 2,55 m		1815 – 2365				72,0