

## Restraint flange adaptors No. 7601, No. 7602

### Preparation:

1. Grease bolts with commercially available lubricant
2. Clean pipe surface

### Assembly:

1. Push the complete flange assembly (incl. clamp, seal and thrust ring) onto the pipe (Fig. 1)
2. Move the complete flange assembly towards the mating flange, taking care that the thrust ring and sealing ring protrude approx. 10 mm beyond the end of the pipe (Fig. 1)
3. Make the flange connection by cross-wise (fig. 2) **and** circular (fig. 3) tightening the bolts (Fig. 4)
4. Be sure to perform a pressure test prior to pipe burial according to EN 805

Edition 05.2017

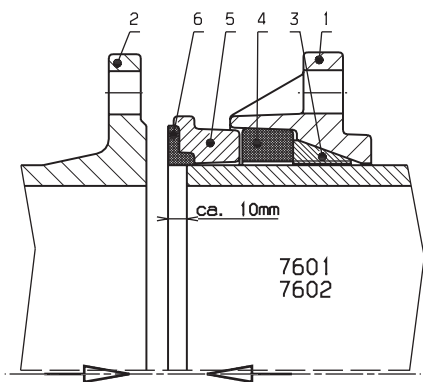

- 1 Restraint flange
- 2 Mating flange
- 3 Locking ring
- 4 Rubber seal
- 5 Thrust ring
- 6 Sealing ring

#### \*Tightening torques for screws:

- M 16** 100 Nm
- M 20** 120 Nm
- M 24** 160 Nm

Fig. 1

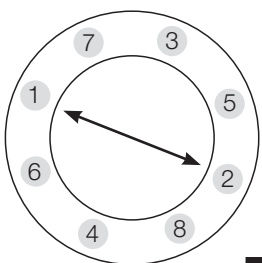

Fig. 2  
cross-wise

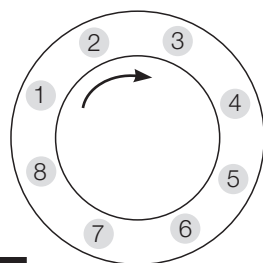

Fig. 3  
circular

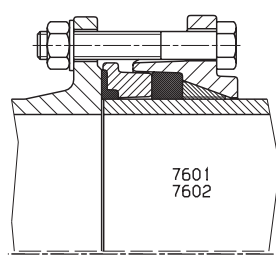

Fig. 4  
Tightened restraint flange

## Restraint flange adaptors No. 7601, No. 7602

### Preparation:

1. Grease bolts with commercially available lubricant
2. Clean pipe surface

### Assembly:

1. Push the complete flange assembly (incl. clamp, seal and thrust ring) onto the pipe (Fig. 1)
2. Move the complete flange assembly towards the mating flange, taking care that the thrust ring and sealing ring protrude approx. 10 mm beyond the end of the pipe (Fig. 1)
3. Make the flange connection by cross-wise (fig. 2) **and** circular (fig. 3) tightening the bolts (Fig. 4)
4. Be sure to perform a pressure test prior to pipe burial according to EN 805

Edition 05.2017

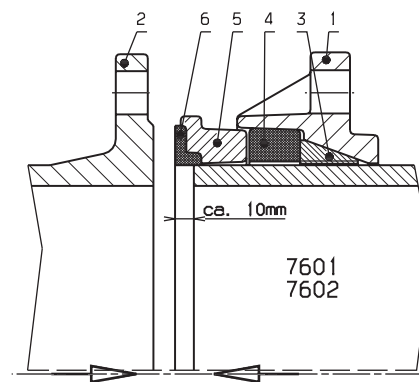

- 1 Restraint flange
- 2 Mating flange
- 3 Locking ring
- 4 Rubber seal
- 5 Thrust ring
- 6 Sealing ring

#### \*Tightening torques for screws:

- M 16** 100 Nm
- M 20** 120 Nm
- M 24** 160 Nm

Fig. 1

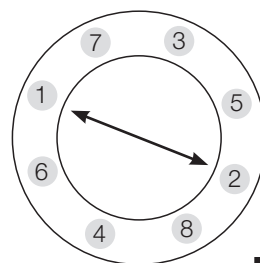

Fig. 2  
cross-wise

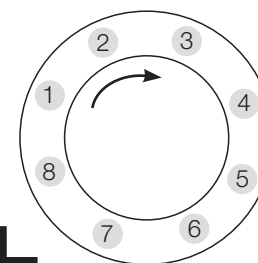

Fig. 3  
circular

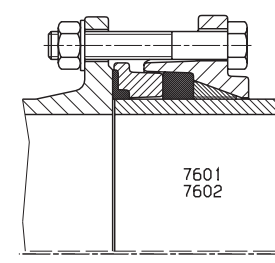

Fig. 4  
Tightened restraint flange