













2022

Hawle-Wastewater catalogue

made for generations.



Hawle-Wastewater catalogue

A	Valves Shut-off devices	
B	Extension spindles Head stocks	
C	Operating material	
D	Air Valves	
E	Flanges and flangeless connections	
F	Pipe Fittings	
G	Sundry equipment	
H	Pipe Saddles	
I	Service Valves Flushing Stand Pipe	
J	Fittings	
K	Tools Technical information	
L	Pipe laying equipment	

A family company with a proud tradition and an eye on the future.

Hawle, a purely family-owned company founded in 1948 is the worldwide leader in the production of an extensive product range of valves and connecting pieces. Hawle is an innovation leader in the development of high-quality valve solutions. In compliance with European and additionally applicable standards, Hawle produces high-performance and durable quality fittings for the construction and the use of water pipelines, as well as the necessary accessories and the required equipment.

Our specialist area of water and wastewater systems also includes customised fittings for special applications and special conditions.

An excellent understanding of the manufacturing process and the production requirements, extensive knowledge in water supply, years of experience and a broad service program enables us to create the optimum product for pipeline connections in all areas of international water supply.

The unique 10 year quality guarantee for Hawle products in the drinking water area confirms our leading position for innovation and quality.

The employees of our company, which has its registered office in Vöcklabruck (Austria), bring all their service and subject knowledge into the research, design, development as well as the production process.

Hawle products are exclusively produced in Europe in the most up-to-date production facilities. More than 98% of the raw materials used in the products come from Europe. Hawle products are manufactured by well-trained specialists, thus guaranteeing careful monitoring of the quality in each phase of the production process. The majority of the components are also produced by Hawle. So the functionality and the quality is assured and guaranteed in each production step.

Hawle stands for high quality, efficiency and durability. Therefore international customers trust in our products and technologies - for generations.

For more details go to **hawle.com**

Hawle - the best solution

a reliable partner

100% Hawle, 100% proven quality

We are constantly striving for improvements together with our partner companies all over the world. In order to achieve this we focus on the requirements of our customers, invest in the most up-to-date technology and offer professional service and technical support.

Hawle has an excellent network of partners, which ensures an efficient and competent distribution of all our products. Our central warehouse in Frankenmarkt, Austria, supplies this network with numerous finished products, which are stored in over 10,000 pallet spaces.

The pipe connections which our technicians develop today will be used tomorrow for your secured water supply.

Hawle offers a competent, round-the-clock service. As soon as we receive your call we immediately put all our efforts into finding a solution to your problem.

made for generations.



Vöcklabruck plant
Austria



Frankenmarkt plant
Austria

Definition of wastewater:

The products listed in the catalogue are intended for stationary installation in wastewater pipelines made from PE, PVC, DCI, steel or AC pipes. Municipal wastewater is defined according to EN 1085. Limit values for wastewater: min. 8.0°dH total hardness, pH value of at least 5 to max. 9.5.

In case of other usage or environmental conditions please let us know about the specific operating conditions with your first query. Our application engineering department will gladly support you with questions about the suitability of products for certain operating conditions.

If our fittings are used outside of the standard applications and without approval of the specific operating conditions by our application technology team we cannot accept any liability.

In such a sensitive area, particular care is naturally given to the product quality, the durability and the functional safety of the products.



Hawle - Guarantee and warranty



5-years quality guarantee (municipal waste water)

E. Hawle Armaturenwerke GmbH (hereinafter referred to as "Hawle") guarantees the function of all valves and fittings manufactured by Hawle with the original "Hawle" inscription, which are used for municipal wastewater as intended in accordance with EN 1085, for a period of 5 (five) years from the date of delivery from our works. However, the maximum guarantee period afforded by Hawle is 6 (six) years from the manufacturing date of the product. In the event of a guarantee claim, it is the responsibility of the customer to prove that the guarantee has not expired, e.g. by presenting the invoice or the original product label.

Should a valve or fitting cease to function during the guarantee period, Hawle shall at its discretion, either repair the product or deliver an equivalent replacement product to the place of performance agreed with Hawle. Hawle will not assume any additional costs or damages incurred by the customer or third parties within the scope of this guarantee. In particular any costs incurred by disassembly, installation, localization or reinstallation shall not be covered by Hawle. Purely optical flaws that in no way impair tightness, tensile strength, nor the operation of the valve or fitting, do not constitute a guarantee claim.

The guarantee also excludes, but is not limited to, wear parts and damage caused by improper storage, transport and assembly, non-compliance with instructions for use, failure to perform pressure tests, utilisation outside the limits of standard applications and general operating parameters, inadequate maintenance, subsequent manipulation or utilisation with unsuitable liquids or gases. The guarantee does not extend to exceptional environmental conditions, vibrations or residues from the medium or similar external influences, including third-party actions, accidents and other events over which Hawle has no influence.

Please also note the exceptions and special regulations applicable to certain products in our catalogue and on our homepage www.hawle.at.

This guarantee is subject exclusively to Austrian law under the exclusion of international conflict of law rules. Any warranty claims arising from the contract of sale shall not be limited by this guarantee.

This guarantee applies to all deliveries as of 01.01.2019 of valves and fittings manufactured by Hawle, which are used as intended for municipal wastewater according to EN1085. Any guarantees or warranties issued by Hawle prior to this effective date shall not be valid for any deliveries made thereafter.



2-year warranty

In addition to our quality guarantees, Hawle warrants in accordance with Austrian law that our products correspond to the relevant contract at the time of delivery. In the event of incorrect storage, transport, assembly, descriptions for use not being observed, failure to pressure-test, insufficient maintenance, subsequent manipulation or usage for non-suitable fluids or gases there is not entitlement to warranty claims. The warranty period runs for a maximum of two years ex-works delivery. Please see the Hawle delivery conditions for further details of the warranty.

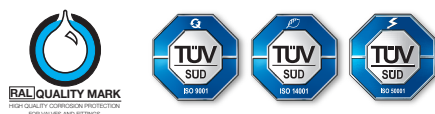

Hawle - **Standard- and special applications**



STANDARD APPLICATIONS:

Our products are intended for stationary installation in wastewater pipelines made of PE, PVC, DCi, steel or AC pipes.

STANDARD MEDIUM:

- **Municipal wastewater**
according to EN 1085

GENERAL OPERATING PARAMETERS:

Municipal wastewater:

Medium temperature: 0 °C to max. 40 °C
max. 250 mg/l Chloride, max. 0.3 mg/l free chlorine
min. 8.0°dH total hardness
pH value of min. 5 to max. 9.5

For the specific operating parameters of our products, please refer to the respective product pages of our catalogue and our homepage **hawle.com**

SPECIAL APPLICATIONS:

In case of deviating conditions of use or ambient conditions, please inform us right on your first inquiry about the specific operating conditions. If you have any questions regarding the suitability of products for certain operating conditions, please contact our Application Engineering department (phone: +43 (0) 7672 72576-0).

If our valves and fittings are used for other than the standard applications and without the approval granted by our Application Engineering department regarding the conditions of use, we cannot assume any liability.

APPLICATION INSTRUCTIONS:

Valves and fittings should be stored in a cool, dry and low-dust environment protected from weather. Avoid exposure to direct sunlight or UV light, unless the valves and fittings are designed for use above ground. For the correct installation and maintenance of our valves and fittings, please observe our instructions as well as the pertinent European standards (EN), as well as the directives of the ÖVGW (the Austrian Association for Gas and Water) and/or comparable national technical standards.

Hawle - Corrosion protection

High quality corrosion protection using the GSK fluidised bed Epoxy coating system.

The environmental friendly solvent and pollution free powder coating technology!

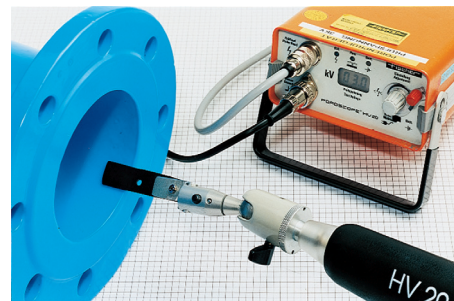
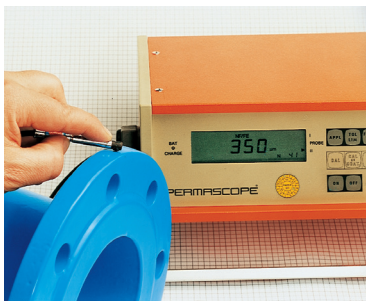
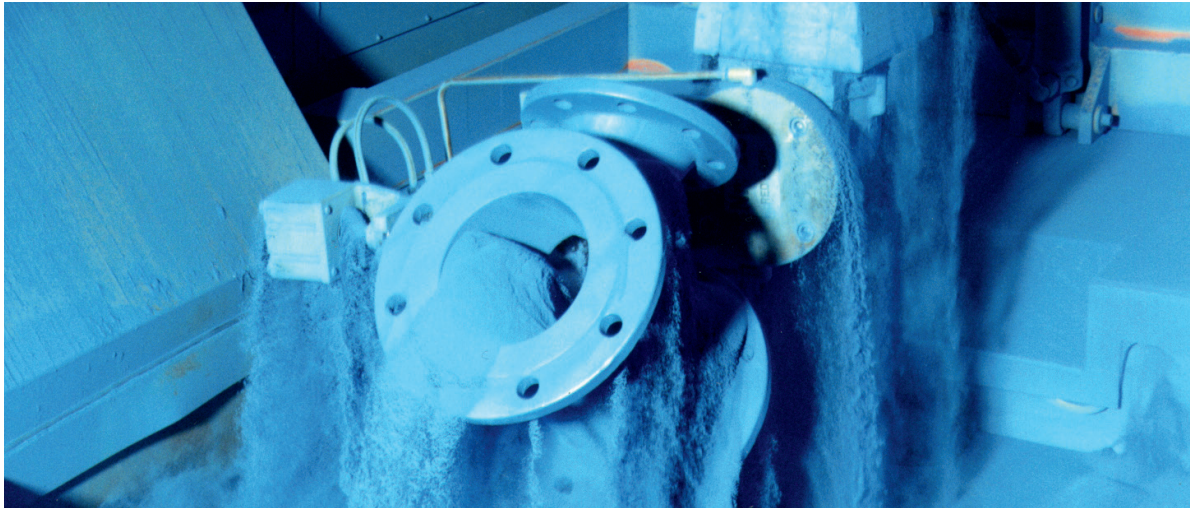

Epoxy Powder-Coated coating according to GSK:

- ⦿ Fulfils the requirements according to EN 14901 (pipes, fittings and accessories)
- ⦿ Minimum coated thickness 250 µm
- ⦿ Zero porosity
- ⦿ High adhesion to metal (min. 12 N/mm²)
- ⦿ High resilience (no cracking)
- ⦿ Smooth surface (makes incrustation more difficult)
- ⦿ Suitable for food use according to the guidelines for hygienic evaluation of organic coating in contact with drinking water (coating guideline) of the German Federal Health Office
- ⦿ High impact resistance
- ⦿ Bacteriological approval to DVGW recommendation W270
- ⦿ Regular quality tests according DIN 3476-1 - coating thickness, adhesion, spark-testing, impact resistance
- ⦿ Independant auditing of quality control systems by MPA Hannover in accordance with the test methods of **GSK (Gütegemeinschaft Schwerer Korrosionsschutz** - the association for high quality corrosion protection)
- ⦿ Hawle standard colour RAL 5012 optional RAL 6037

Wastewater - Knife Gate Valve

With loose flange

Design features

- The ideal gate valve for the replacement of existing valves and new construction of pressure lines
- Spindle lies outside the flow medium
- Reliable and leak-proof shut-off function by knife gate and O-ring seal
- Can be used for installation in plants and underground installation
- Restraint connection
- Bonnet can be replaced "under pressure" (up to DN 200)
- Flat gaskets are already contained in the conical seals

Material | Technical features

- **All cast iron parts** made of ductile iron, epoxy powder coated
- **Spindle, knife gate** made of stainless steel
- Face-to-face length according to EN 558 GR 14
- Max. operating pressure MOP (PN) 10
- Note: actuation by means of electric actuator on request
- Flanges sized in accordance with EN 1092-2, drilled according to EN 1092-2 | PN 10 standard; EN 1092-2 | PN 16 DN 200 please specify on order - other standards on request

Suitable accessories

Handwheel:		No. 7800 ⁺
Extension spindles:	rigid	No. 9000 ^{E2} ⁺⁺
	telescopic	No. 9500 ^{E2} ⁺⁺

⁺ check the spindle square „VK“

⁺⁺ note the footnote below the table

No. 4806

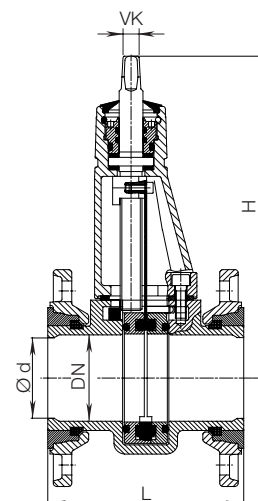

Application example

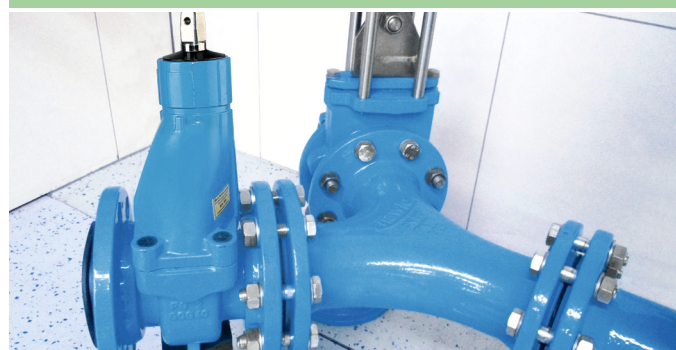

DN	MOP (PN)	H	L	Ø d	VK	Weight
80	10	295	180	76	14,8*	14,00
100		320	190	96	14,8*	17,00
125		424	200	121	17,3**	27,00
150		410	210	145	17,3**	32,00
200		530	230	172	19,3***	45,90
250		832	250	247	27,3	150,00
300		807	270	297	27,3	178,00

* When using an **E2** extension spindle (9000**E2** / 9500**E2**) use DN 50 - DN 100 spindle adapter 5008748.

** When using an **E2** extension spindle (9000**E2** / 9500**E2**) use DN 50 - DN 100 spindle adapter 5008752.

*** When using an **E2** extension spindle (9000**E2** / 9500**E2**) use DN 150.

Wastewater - Knife Gate Valve

With loose flange

Application example

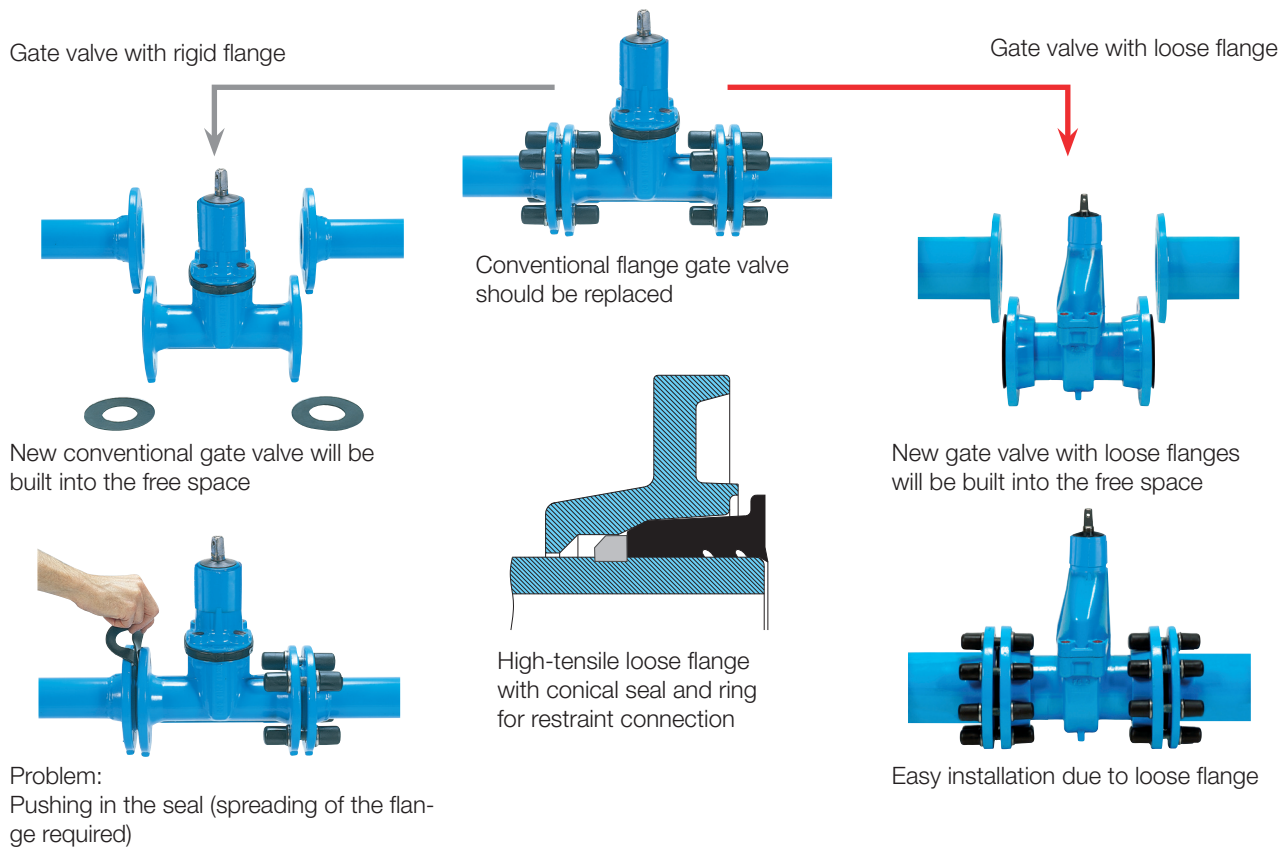

This knife gate valve was specially built for the replacement of existing valves in wastewater pressure lines. Previously it was extremely time-consuming to replace such a gate valve (see application example above)!

This sewage gate valve is provided with loose flanges and can easily be installed in the free space created

Recommended approach:

1. Disassembly of the existing gate valve
2. Check the sealing surfaces of the counterflanges, clean if necessary
3. Reset loose flange and adapt the replacement gate valve to the free space
4. Set-up the loose flange and mount on counterflange

Benefits

- No spreading apart of the flange required
- Highly time-saving compared to the installation of conventional gate valves
- Easier installation due to moving loose flange
- Integrated conical seal with sealing lips and flat gasket
- Restraint connection
- Single-handed tightening of the screws due to hexagonal recess

Universal Pipe Saddle

With integrated flange knife gate valve



No. 4807

Design features

- For lateral drilling of wastewater lines made from cast iron, steel (AC pipes) under pressure (DN 150-500)
- Spindle lies outside the flow medium
- Reliable and leak-proof shut-off function by knife gate and O-ring seal
- Suitable for underground installation
- Bonnet can be replaced "under pressure"
- **Two straps** and an additional saddle seal are always required!

Material | Technical features

- **All cast iron parts** made of ductile iron, epoxy powder coated
- **Spindle, knife gate** made of stainless steel
- One side with double strap connection, the other side with flange in accordance with EN 1092-2
- Max. operating pressure MOP (PN) 10
- Note: actuation by means of electric actuator on request
- Flange sized and drilled according to EN 1092-2 | PN 10 standard - other standards on request

Suitable accessories

Handwheel:		No. 7800 ⁺
Extension spindles:	rigid	No. 9000 E2
	telescopic	No. 9500 E2
Strap:		No. 3110
Saddle seal:		No. ND82

⁺ check the spindle square „VK“

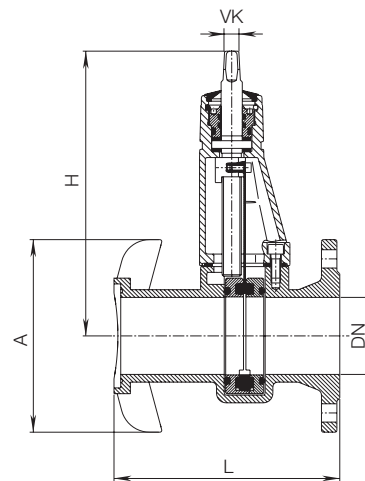

DN	MOP (PN)	A	H	L	Drill Ø max.	VK	Weight
80	10	200	590	245	75	14,8*	17,4

* When using an **E2** extension spindle (9000**E2** / 9500**E2**) use DN 50 — DN 100 spindle adapter 5008748.

Auxiliary Shut-off Flange

Design features

- Shut-off adapter for combination with air release valves

Material | Technical features

- **Housing** and **dirt cover** made of steel, epoxy powder-coated
- **Seals:** integrated O-ring seals
- **Threaded bolts** made of stainless steel
- Max. operating pressure MOP (PN) 16
- Flange drilled according to EN 1092-1 | PN 16 standard

Suitable accessories

Saddle blade:

No. 8401

No. 3735

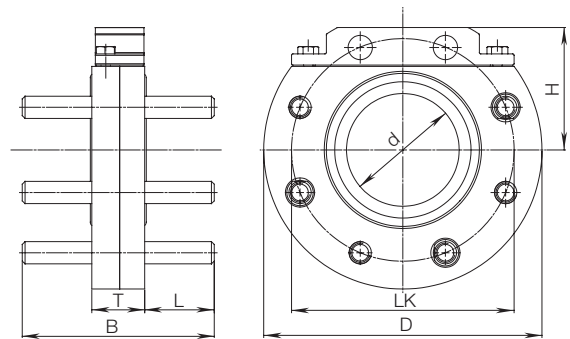
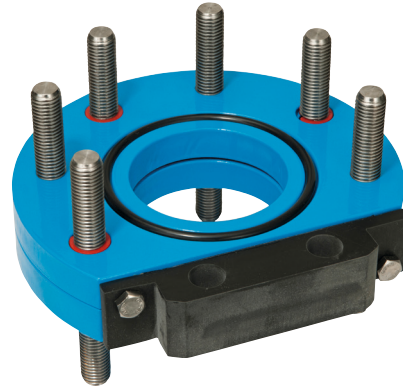

Application example



DN	MOP (PN)	D	d	LK	H	B	L	T	Weight
80	16	200	80	160	88	138	50	38	6,90

Knife Gate Valve

With non-rising spindle

Design features

- Tight on both sides
- Gate valve for various applications
- Strong gate valve construction ensuring high resistance to corrosion
- Operation by handwheel or optional electric drive – be sure to specify when ordering
- One-piece body for DN50 - DN200, above DN200 a two-piece body
- Face to face according to EN 558 GR 20
- Maximum operating pressure 10 bar or 6 bar (see table)

Standard version:
with non-rising spindle

Variants of execution:

- with a connection for an electric drive (cat. No. 3600EL)
- with connection to a pneumatic drive (catalog no. 3600PN)
- with a pneumatic drive (catalog no. 3600PM)

Material | Technical features

- **Body:** grey cast iron, conforming to EN 1561, epoxy powder coated
- **Bearing:** DN50 - DN200: ductile cast iron, DN250 - DN400: grey cast iron
- **Knife plate:** Stainless steel
- **Spindle and columns:** Stainless steel
- **Hexagonal bolts:** Stainless steel
- **Spindle nut:** Bronze
- **Seals:** elastomer
- **Slip washer:** POM

Suitable accessories

Handwheel: No. 7800
 Actuator: No. 9920
 Spindle extension: No. 7820

No. 3600

with non-rising spindle

No. 3600EL

with flange connection for electric actuator

No. 3600PN

with flange connection for pneumatic actuator



DN 50 - 200

DN 250 - 400

Order No.	Version	MOP PN	Dimensions / DN												
			50	65	80	100	125	150	200	250	300	350	400		
3600	with non-rising spindle	10													
		6*													
3600EL	with a connection for an electric drive	10													
		6*													
3600PN	with connection to a pneumatic drive	10*													
		6*													
3600PM	with a pneumatic drive	10													
		6*													

* drilling is according to EN 1092-2 PN10 / maximum operation pressure PN6

Application example

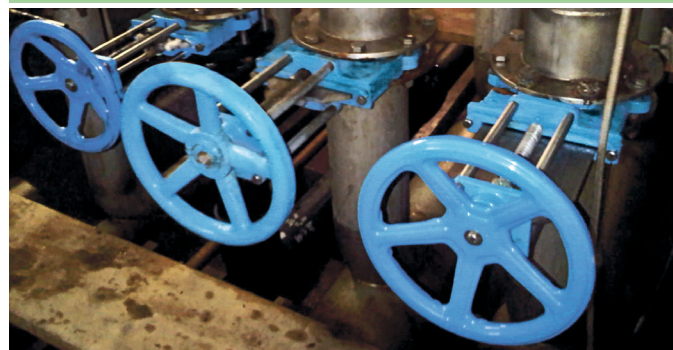

Knife Gate Valve

With non-rising spindle

No. 3600

with non-rising spindle

No. 3600EL

with flange connection
for electric actuator

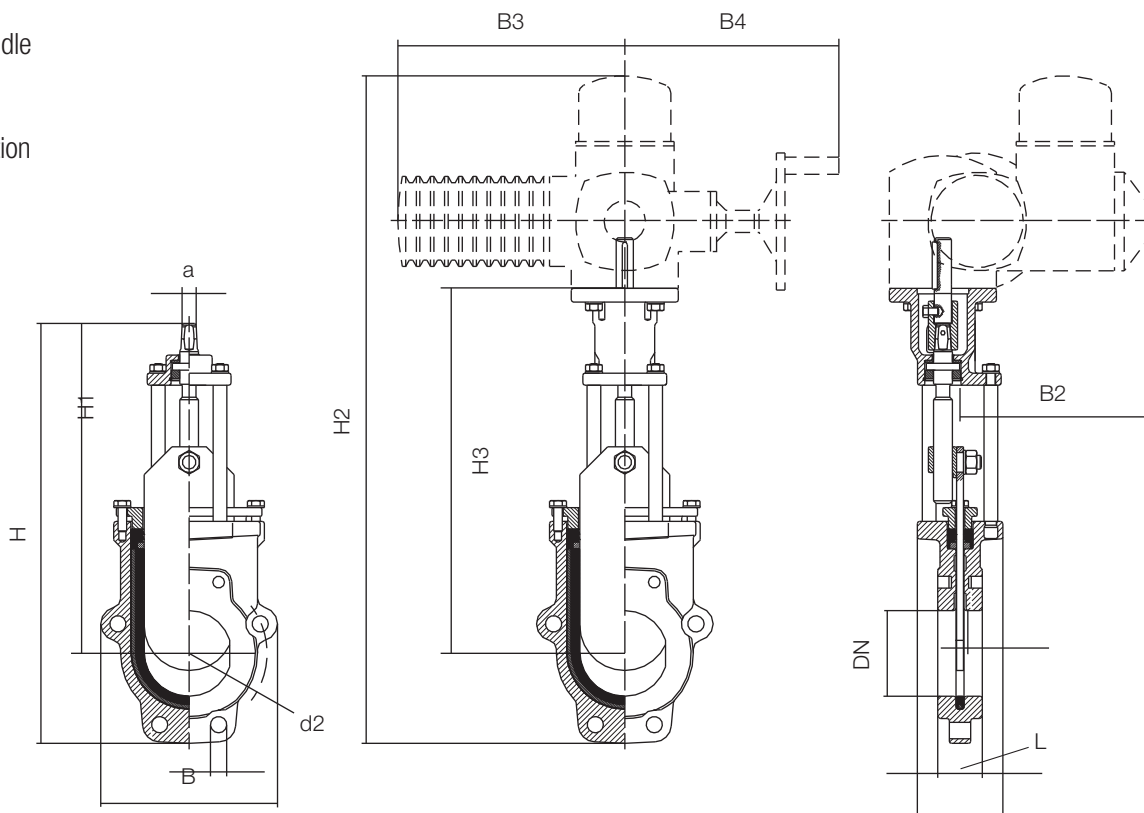

DN	50	65	80	100	125	150	200	250*	300*	350*	400*
MOP (PN)				10				6	6	6	6
Thread	M16	M16	M16	M16	M16	M20	M20	M20	M20	M20	M24
Through bores holes	2	2	6	6	6	6	6	8	8	10	10
Blind tapped holes Quantity/Side	2	2	2	2	2	2	2	4	4	6	6
Blind tapped holes Depth t	9,5	11,0	10	13	14	14	14	14	19	19	26
k	125	145	160	180	210	240	295	350	400	460	515
d2	19	19	19	19	19	23	23	23	23	23	28
H	349	381	450	490	559	619	753	957	1081	1242	1353
H1	284	309	355	385	439	483	591	788	888	1016	1103
H2			779	819	892	952	1088	1296	1420	1610	1721
H3			396	426	484	528	636	837	937	1068	1155
B	125	1139	188	206	234	268	319	347	399	462	512
B1	88	88	100	100	100	100	127	160	160	180	180
B2			273	273	273	273	287	279	279	318	318
B3			265	265	265	265	282	282	282	385	385
B4			250	250	250	250	256	256	256	325	325
L	43	46	46	52	56	56	60	68	78	78	102
Spindle square a	10,3	10,3	14,8 (19,3**)	14,8 (19,3**)	19,3	19,3	19,3	24,3	24,3	27,3	27,3
Open/Close revolutions			8	10	13	15	20	21	25	29	34
Weight No. 3600	6,3	7,0	11,0	14,0	14,0	22,0	33,0	73,0	99,0	140,0	180,0
Weight No. 3600EL			13,0	16,0	19,5	24,5	36,0	76,0	102,0	144,0	184,0
Suitable handwheel*** No.7800DN	2"	2"	100	100	125 - 150	125 - 150	125 - 150	200	200	250 - 350	250 - 350

* Range drilling PN10/operating pressure PN6

** with spindle adapter

*** not included in scope of delivery

Knife Gate Valve

With non-rising spindle

No. 3600PN

with flange connection
for pneumatic actuator

No. 3600PM

with the pneumatic actuator

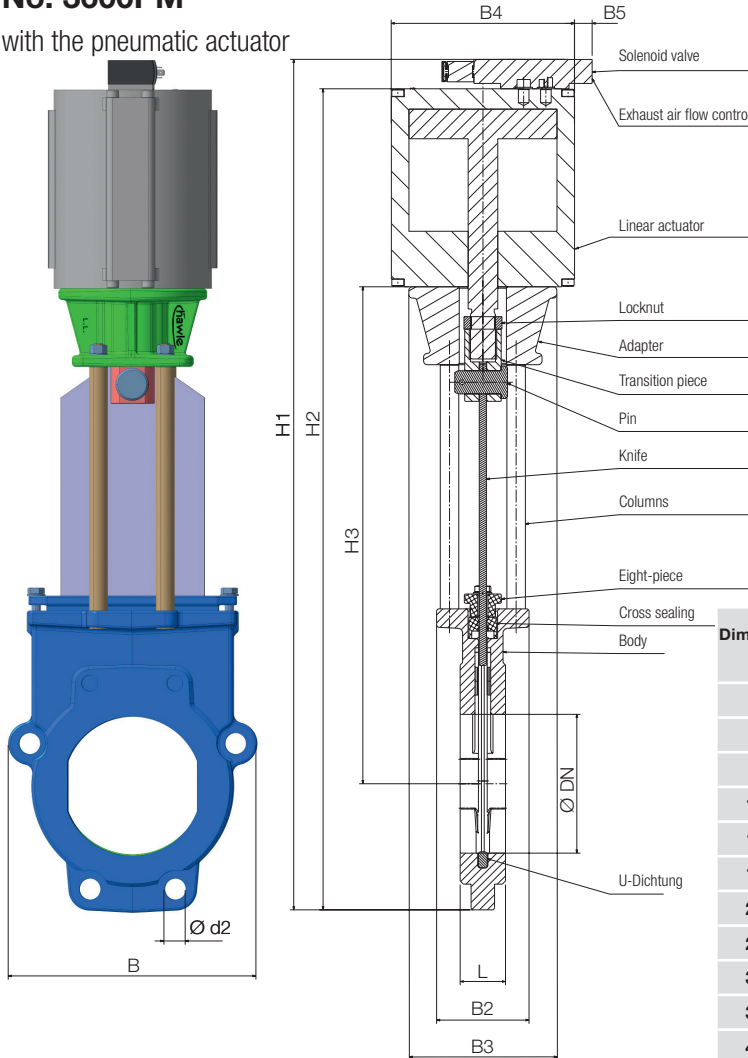

Parts	Material
Body	Grey cast iron, Ductile iron
Cross sealing	Elastomer
U-sealing	Elastomer
Eight-piece	Grey cast iron
Columns	Stainless steel
Knife	Stainless steel
Transition piece	Stainless steel
Pin	Stainless steel
Linear actuator	Festo
Adapter	Ductile iron
Locknut	Stainless steel
Bolts	Stainless steel
Solenoid valve	Festo
Exhaust air flow control	Festo

Dimension DN	Pneumatic driver	Recommended closure time** (sec)	Adapter	Pin	Transition piece
50	DLP(DFPC*)-80-50-A	3	Type A1	Type A	Type A1
65	DLP(DFPC*)-80-65-A	3		Type A	Type A1
80	DLP(DFPC*)-100-80-A	5		Type B	Type A2
100	DLP(DFPC*)-100-100-A	5	Type B1	Type C	Type B1
125	DLP(DFPC*)-160-150-A	5			Type B1
150	DLP(DFPC*)-160-200-A	6	Type B2	Type D	Type B2
200	DLP(DFPC*)-160-200-A	6			Type B2
250	DLP(DFPC*)-160-200-A	11	Type C1	Type D	Type C1
300	DLP(DFPC*)-160-200-A	15			Type C1
350	DLP(DFPC*)-160-200-A	18	Type C2	Type D	Type C2
400	DLP(DFPC*)-160-200-A	26			Type C2

* on request

** with exhaust air valve control

	DN50	DN65	DN80	DN100	DN125	DN150	DN200	DN250	DN300	DN350	DN400
B	125	139	188	206	234	268	319	347	399	462	512
B2	88	88	100	100	100	100	127	160	160	180	180
B3	129	129	129	129	160	160	160	244	244	244	244
B4/B4*	108/94	108/94	131/108	131/108	199/170	199/170	199/170	271/211	271/211	308	308
B5/B5*	19/58	19/58	19/58	19/58	19/58	19/58	19/58	0/58	0/58	0/58	0/58
L	43	46	46	52	56	56	60	68	78	78	102
H1/H1*	523/508	570/545	649/622	708/681	832/819	908/895	996/983	1397/1391	1601/1595	1775/**	1933/**
H2/H2*	491/476	538/513	617/590	676/649	800/787	876/863	964/951	1365/1359	1569/1563	1745/**	1903/**
H3	286	311	347	377	442	486	489	796	896	1019	1106
Ø d2	19	19	19	19	19	23	23	23	23	23	28

* dimensions for pneumatic drive DFPC (matching with DFPC drive on request)

** size on request

The optimal air pressure values for the operation of gate valves with actuators are 5.5 - 7.0 bar.

Average air flow for valves in the range of 950 l / min. - 1350 l / min.

Knife Gate Valve

With non-rising spindle

Recommended solenoid valves according to the possibility of connection to air supply.

Types of valves depending on the application

- Standard Namur solenoid valves VSNC, mounted directly on the actuator
- VUVS series universal solenoid valve assembled individually
- Manually actuated valves VHEF
- Valve terminal with multi-pin or fieldbus connection

Basic types of solenoid valves:

- located on the actuator
- located outside the drive
- integrated

Functions of solenoid valves

- 5/2 monostable (single solenoid valve, spring return)
- 5/2 bistable (double solenoid valve)
- 5/3 mid-position pressurised

Additional equipment:

- Direct mount actuator sensors
- (SMT, CRSMT) - signaling of end positions or intermediate drives
- DADG adapter for mounting a Namur VSNC valve
- or position sensor directly on the DFPC actuators

Other accessories on request

No. 3600PN

with flange connection for pneumatic actuator

No. 3600PM

with the pneumatic actuator

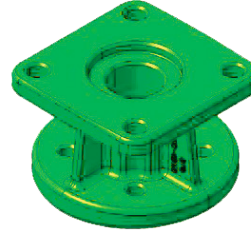

A1 + A2

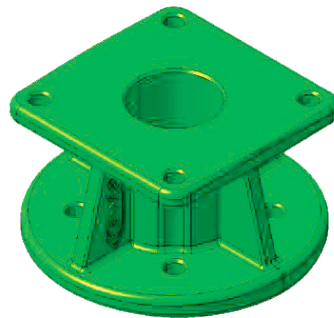

B1 + B2

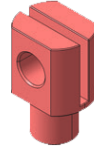

Type
A1+ A2

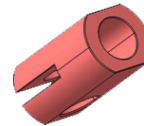

Type
B1+ B2

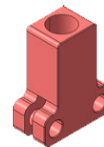

Type
C + D

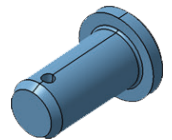

Type
A + B + C

In order to use a knife gate valve with a pneumatic actuator from another manufacturer, please contact the Hawle technical department.

Extension Spindles

Rigid or telescopic

Design features

- One extension spindle for several dimensions
- Threaded connection for attachment to the service valve
- No additional fixing (bolt/pin) necessary

Order No.	Version	Pipe cover (RD)	¾" - 2"
9101	rigid	0,75 m	
		1,00 m	
		1,25 m	
		1,50 m	
		2,00 m	
		2,50 m	
9601	telescopic	0,60 – 0,80 m	
		0,80 – 1,20 m	
		1,00 – 1,60 m	
		1,30 – 1,80 m	
		1,80 – 2,50 m	
		2,50 – 3,50 m	

Suitable accessories

- **Extender for rigid spindle**
Order No. 7830 price for first meter
Order No. 7831 price for each additional half meter
- Please specify dimensions and length when ordering

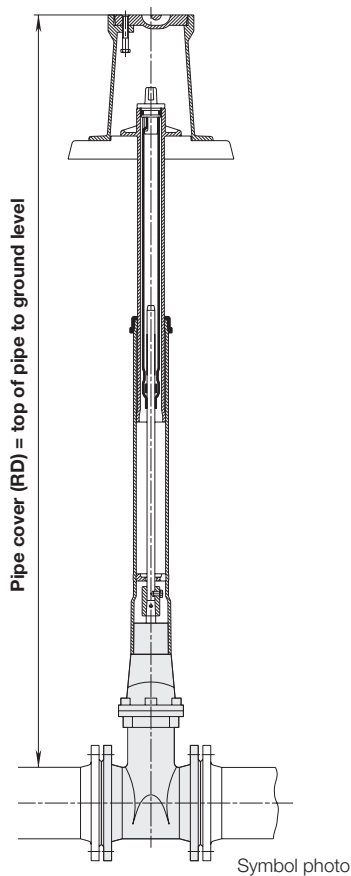

Extension spindle for service valves with threaded connection for spindle DN ¾" - 2"

No. 9101

Rigid

No. 9601

Telescopic

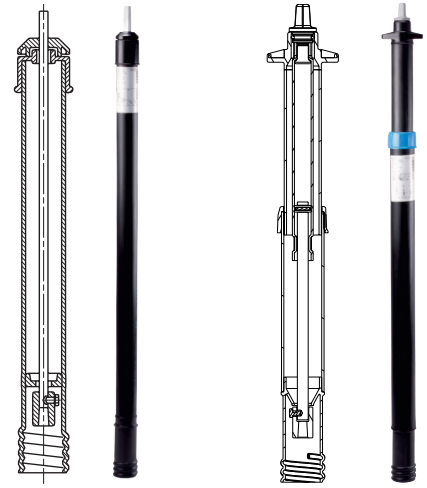

Rigid

Telescopic

Spindle head | square

	For service valves	For gate valves
a	13 mm	27 mm
b	15 mm	32 mm
c	24 mm	48 mm

Order No.	Version	Pipe cover (RD)	Weight
9101	rigid	0,75 m	1,20
		1,00 m	1,70
		1,25 m	2,20
		1,50 m	2,70
		2,00 m	3,70
		2,50 m	4,70
9601	telescopic	0,60 – 0,80 m	3,50
		0,80 – 1,20 m	4,90
		1,00 – 1,60 m	3,20
		1,30 – 1,80 m	2,40
		1,80 – 2,50 m	1,60
		2,50 – 3,50 m	6,90

E2 Extension Spindle

Rigid or telescopic

Design features

- One extension spindle for several dimensions
- Protective cover with integrated locking mechanism
- No additional fixing (bolt/pin) necessary
- DN 50 to 200

Order No.	Version	Pipe cover (RD)	Dimensions/DN		
			50/65/80/100	125/150	200
9000E2	rigid	1,00 m			
		1,25 m			
		1,50 m			
		2,00 m			
		2,50 m			
9500E2	telescopic	1,30 – 1,80 m			
		1,35 – 1,80 m			
		1,80 – 2,50 m			
		2,50 – 3,50 m			

Suitable accessories

- **Extender for rigid spindle**
Order No. 7830 price for first meter
Order No. 7831 price for each additional half meter
- Please specify dimensions and length when ordering

For gate valves No. 4806, 4807
DN 50 – 200

No. 9000E2
Rigid

No. 9500E2
Telescopic



Spindle head | square

	For service valves	a 13 mm
		b 15 mm
		c 24 mm
	For gate valves	a 27 mm
		b 32 mm
		c 48 mm

9000E2	Weight Extension spindles, rigid – for DN		
RD*	50/65/80/100	125/150	200
1,00 m	3,50	2,80	2,70
1,25 m	4,50	3,70	3,50
1,50 m	5,50	4,80	4,50
2,00 m	7,45	6,60	6,50
2,50 m	9,40	8,60	8,50

9500E2	Weight Extension spindles, telescopic – for DN		
RD*	50/65/80/100	125/150	200
1,30 - 1,80 m	6,60	6,25	
1,35 - 1,80 m			6,10
1,80 - 2,50 m	9,50	8,90	8,60
2,50 - 3,50 m	12,80	12,00	11,90

RD* = pipe cover

Assembly E2 installation kit DN 50 - 200

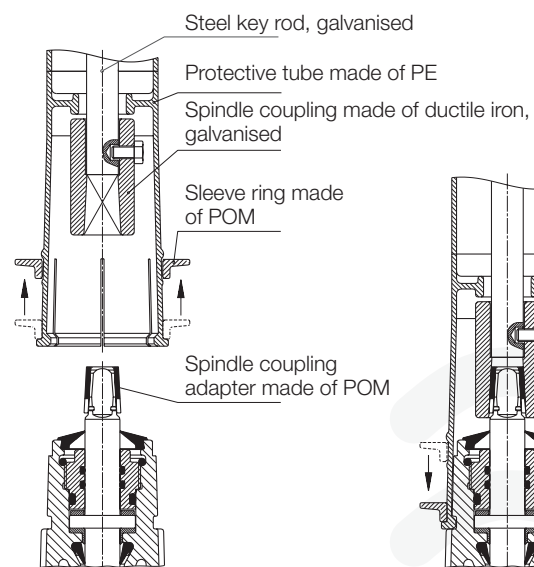

Design features

- For the ergonomic above-ground operation of shut-off valves buried in the ground or installed in manholes and valve chambers
- Standpipe and connecting flanges of stainless steel
- Connecting flange for fixing on support base DN 65 drilled to EN 1092
- Electric actuator see page C 1/2

Material | Technical features

Version with handwheel (No. 9894)

- The extended inner pipe made from galvanised steel allows quick and easy connection of the HAWAK-Pillar with the square rod of the spindle extension or extension spindle. The telescopic connection in the HAWAK-Pillar allows a generous tolerance when cutting the square rod to length
- **Spindle** made of stainless steel
- **Spindle bearing** made of POM
- **Wiper ring** made of elastomer
- Position indicator for monitoring of valve position
- Maintenance-free

Version for electric actuator (No. 9895)

- Connecting flange for actuator according to EN ISO 5210 / DIN 3210

Pillar

No. 9894

No. 9895



No. 9894

No. 9895

Order No.	Version	For valves of nominal widths / DN											
		50	65	80	100	125	150	200	250	300	350	400	
9894	Equipped with handwheel and position indicator												
9895	Model with connection for electric actuator												

When ordering please specify the valve type and the nominal width

Additional extension spindle

Material | Technical features

- Material: galvanised steel
No. 7820 price for first meter
No. 7821 price for each additional half meter
- Material: stainless steel
No. 7825 price for first meter
No. 7826 price for each additional half meter
- Specify overall length „L“ when ordering !
- Installation on gate valves under Hawak pillar

No. 7820

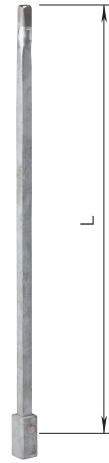

Order No.	Version	Dimensions/DN							
		¾"-2"	50	65	80	100-150	200	250-300	400
7820 7821	galvanised steel								
7825 7826	stainless steel								

Operating Material

Design features

- No. 7800 Handwheel for house connection valves and gate valves
- For wastewater knife gate valve No. 4806 Handwheel according to VK slider spindle and not according to DN choose

Material | Technical features

- DN 2" — 200 made of ductile iron, epoxy powder coated (steel on request)
- DN 250 — 350 made of steel, epoxy powder coated
- DN 400 made of grey iron

Handwheel No. 7800

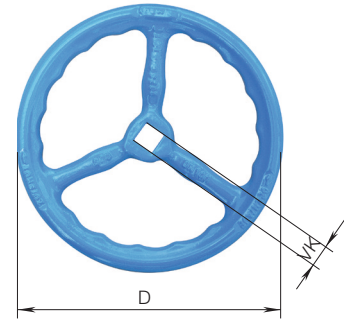

Order No.	DN	D	VK slider spindle	Weight
7800	¾" — 2"	140	10,3	0,28
	50	160	14,8	0,39
	65 — 80	190	17,3	0,80
	100	240	19,3	0,97
	125 — 150	320	19,3	1,88
	200	360	24,3	2,69
	250 — 350	486	27,3	4,82
400	600	32,3	6,50	

Design features

- Adapter for actuation by Operating key No. 3410/3420
- Protection for valve spindle square
- Made of aluminum, with cap and direction indicator

Material | Technical features

- No. 2157 „clockwise closing“ - red
- No. 2158 „anti-clockwise closing“ - blue
- No. 2156 made of ductile iron, galvanised

Operating cap



No. 2157



No. 2158



No. 2156

Order No.	Dimensions/DN							
	20-40	50	65	80	100-150	200	250-350	400
2157								
2158								
2156								

Actuator

Design features

- In standard version 400 V, 50 Hz, three phase motor, easily adjustable limit switch, dual torque switch, signal output to control flasher, thermoswitch for motor protection, handwheel for emergency use.
- Connection according: EN ISO 5210 F10 / F14
- Shaft coupling: EN ISO 5210 B3
- Enclosure of actuator: IP 68
- Enclosure of switches: IP 66
- Variations from the standard version on request.

Actuator No. 9920

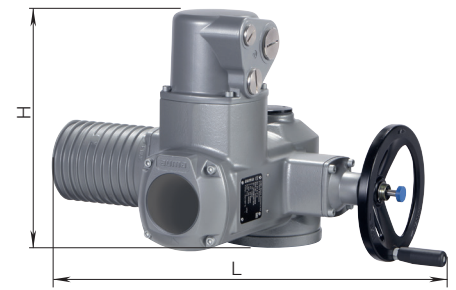

Actuator control unit AUMA MATIC and AUMATIC on request

Knife Gate Valve		Actuator					
DN	MOP (PN)	Type	Max. torque	L	B	H	Weight
50-150	16	SA 07.6	60	514	300	288	21,0
200-300		SA 10.2	120	536	312	290	23,5
350-400		SA 14.2	250	725	375	316	50,0

DN	Actuator U/min	~ Closing time
50-100	16	0,5 min
125-150	16	1,0 min
200-300	22	1,0 min
350-400	22	1,5 min

Other closing times and versions on request!

Please observe when ordering:

For the use of Hawle knife gate valves with built-in electric actuator, the following data must be made known when ordering:

1. Operating pressure
2. Installation location of the valve
3. Number of on/off control communications per 24 hours

Automatic Air Valve

For wastewater, operating pressure of 0 – 16 bar



Design features

- Direct automatic air inflow and release valve for wastewater
- Operates automatically
- Max. air release capacity: 440 m³/h
- Max. size of the opening: 480 mm²
- Sealing face is not in contact with the wastewater
- The two joints facilitate easy and excellent flushing at maintenance. The flushing water is introduced via the upper exhaust opening. Solids are flushed out via the ball valve connector
- All mechanical parts of corrosion resistant materials
- Flanges sized in accordance with EN 1092-1, drilled according to EN 1092-1 | PN 10 standard; EN 1092-1 | PN 16 DN 200 please specify on order - other standards on request
- Due to the direct operation the release of lots of air is possible, even under full working pressure
- Subsequent special functions on request:
 - only air release
 - Air release stop: for compressed air tested lines (see page D 1/3)
- Please take the direction and maintenance instructions into consideration

Valve maintenance

Operating and maintenance Instructions see Homepage

Suitable accessories

Air release stop:		No. 9862
Functional unit	No. 9863:	Order No. 5014027
	No. 9864:	Order No. 5014043

No. 9864
No. 9863



Application example

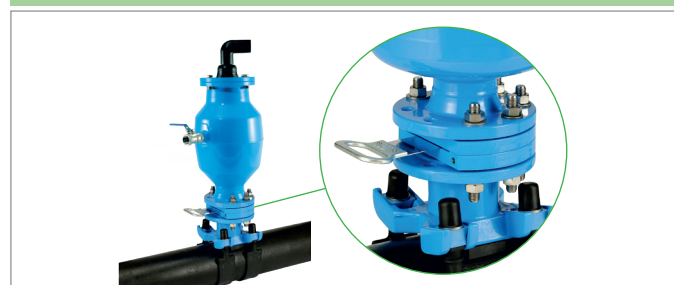

Functional unit suitable for:



Order No.	Version	Medium	MOP (PN)	Dimensions/DN					
				2"	50	80	100	150	200
9864	stainless steel with flange connection	Wastewater	0 – 16						
9864	stainless steel with 2" internal thread connection ISO 228								
9863	Steel, epoxy powder-coated with flange connection								
9863	Steel, epoxy power-coated with 2" internal thread connection								

Automatic Air Valve

For wastewater, operating pressure of 0 – 16 bar

Flange / ID DN	B	H	Weight
2"	273	615	21,5
50		625	23,5
80			24,5
100			25,5
150			26,5
200			33,5

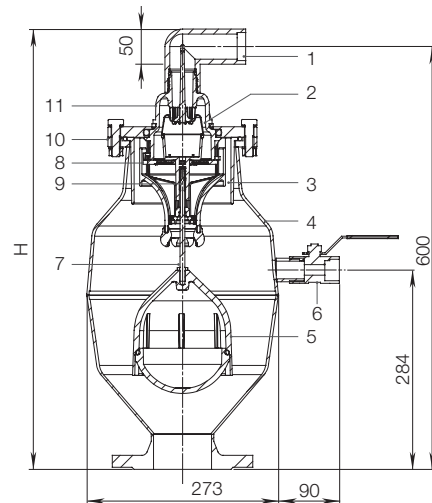

Part	No. 9864 version stainless steel	No. 9863 version steel-coated
1 Outlet elbow with dirt sieve	PE / stainless steel	PE / stainless steel
2 Diaphragm	Elastomer	Elastomer
3 Protector	PE	PE
4 Body	Stainless steel	Steel, epoxy powder-coated
5 Float	POM	POM
6 Ball valve outlet 1"	Stainless steel	Stainless steel
7 Rod	Stainless steel	Stainless steel
8 Body nut with sieve	POM / stainless steel	POM / stainless steel
9 Diaphragm holder	POM	POM
10 Fix flange	Stainless steel	Steel, epoxy powder-coated
11 Valve body-bonnet	POM	POM
Bolts, nuts and springs	Stainless steel	Stainless steel

Flow performance diagramm

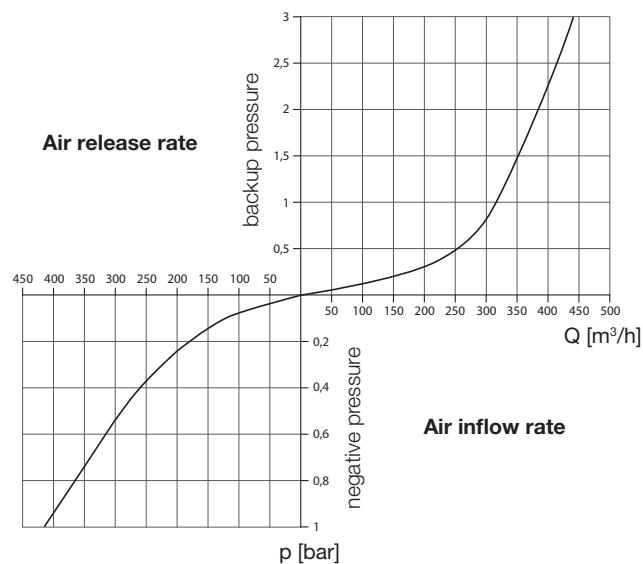

Automatic Air Valve

With air release stop

Design features

- An escape of the flushing air via the automatic air valve is not desired during compressed air flushing. For this reason Hawle has developed an air release which can be subsequently mounted on each valve or can be built into each set
- When a certain air release capacity is reached (continuously adjustable via the adjustment nut), the air release closes and the flushing air remains in the pipe, only a small amount of air escapes through the overflow hole. After the flushing process has finished, the pressure builds up via this overflow hole, the exhaust stop opens and the automatic air valve returns to normal operation. Through a damping element the taper closes with a time delay, i.e. the valve is not immediately triggered for each short-term air release process with large air release performance and closes
- The air release quantity through the overflow hole is infinitely adjustable by means of a perforated adjusting screw

Material | Technical features

- Medium: drinking water, wastewater
- Max. operating pressure MOP (PN) 16
- Material:
Body and **sealing cone** made of POM
Axis, spring and **adjusting nut** made of stainless steel
Sealing elements made of elastomer
- Prevents the escape of flushing air during the compressed air flushing
- Can be mounted before installation or subsequently on Hawle automatic air valves
- Infinitely variable adjustment of the air flow for the closing process
- If no compressed air flushing is carried out, the valve works in the normal operating condition

Air release stop No. 9862

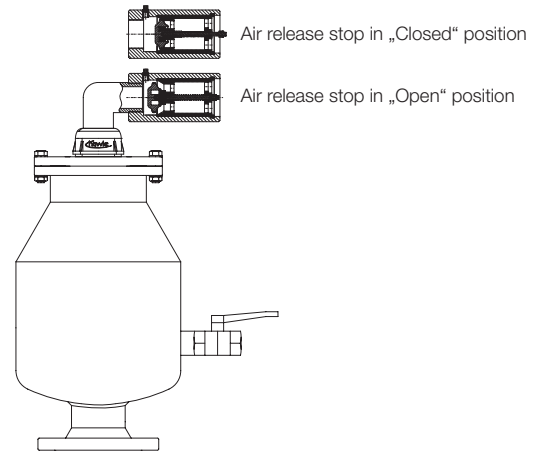

Wastewater automatic air valve with air release stop

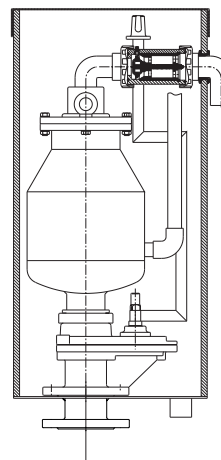

Wastewater automatic air release valve with air release stop

Automatic Air Valve

For wastewater, operating pressure 0 – 16 bar

Design features

- Waterproof PE-chamber with shut-off valve, air valve and fitting for connection of a PE drainage line
- Self - actuating
- Seal seat is not in contact with the wastewater (air cushion)
- Two connectors for efficient flushing during maintenance work (upper connector = flushing water inlet)
- When using with compressed air flushing an additional air release stop is required

Material | Technical features

- **Body** made of steel, epoxy powder-coated (alternatively in stainless steel version)
- **All mechanical parts** made of corrosion-resistant materials, **body** made of steel, epoxy powder-coated
- Max. air release capacity: 440 m³ / h
- Flange sized and drilled according to EN 1092-2 | PN 16 other standards on request
- Max. operating pressure (PN) 0 - 16

Suitable accessories

Manhole cover and ring: No. 2069
Air release stop: No. 9862

No. 9828 with flange



Flange

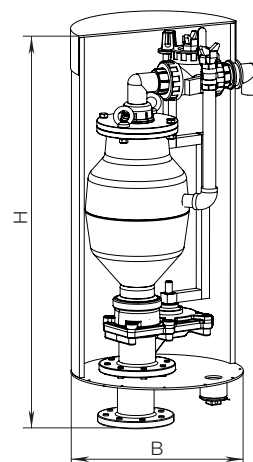

Application example

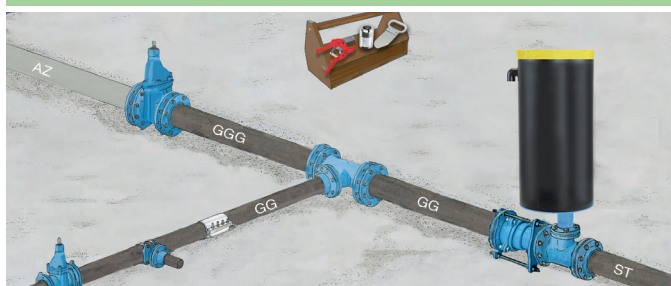

Order No.	MOP (PN)	Flange DN	H	RD	B	Weight
9828	16	80	990	1,25	455	62,0
			1240	1,50		80,0

FITTINGS FOR PE AND PVC PIPES

Restraint, System 2000

Design features

- Using a lip seal ring for sealing the pipe allows for easier insertion of the pipe into the System 2000 chamber
- The pipe restraining system is required for pushing the pipe and into the seal chamfer with an appropriate chamfer
- For PE pipes with thin walls (up to 3 mm wall thickness) and low internal pressure we recommend using a support liner
- Suitable for **PE pipes 80/100**, EN 12201, DIN 8074
- For **PVC pipes** according to EN ISO 1452-2

Material | Technical features

- **Body and lock ring** made of ductile iron, epoxy powder coated
- **Grip ring** made of brass (from DN 300 bronze)
- **Hexagonal bolts** made of stainless steel
- **Lip seal ring** made of elastomer
- **Spacer bushes** made of PE

System 2000

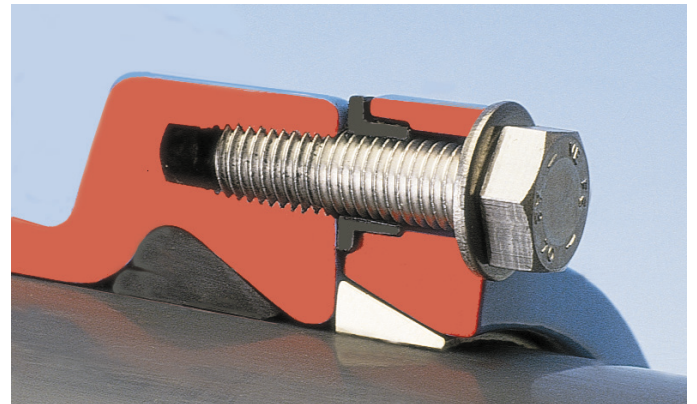

Push socket for PE- (PE 80/100, EN 12201, DIN 8074) **and PVC pipe** (EN ISO 1452-2) - absolutely restraint

Flange No. 0400

equal and reduced
with integrated flange seal
DN 50 – 600



Connector No. 0430

Ø Pipe 63 – 355



Duck foot bend No. 5045

DN 80, DN 100



End cap No. 8075

Ø Pipe 63 – 315



All socket tee No. 8515

equal and reduced side outlet
Ø Pipe 63 – 225



Double socket tee No. 8525

equal and reduced side outlet
Ø Pipe 63 – 225



Bend

No. 8535 90°

No. 8545 45°

No. 8555 30°

No. 8557 11°

Ø Pipe 63 – 315



Fittings for PE and PVC pipes

Restraint, System 2000

ASSEMBLY INSTRUCTIONS:

For flange adaptors:
bolt the flange to the mating flange first

Chamfer the pipe -
use lubricant No. 3443
(see page L 2/2)
Do not use oil!

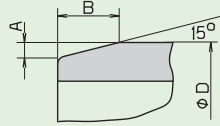

Ø D	A	B
63 – 40	2,5	10
160 – 180	4,0	16
200 – 225	5,0	20
250 – 315	7,0	25
355 – 450	9,0	35
500 – 630	10,0	40

Push the pipe to the end of the socket

For PE pipes with thin walls (\geq SDR 21) and low internal pressure we recommend using a support liner

Tighten the lock ring bolts crosswise until lock ring is tight on bushes
Max. tightening torque for lock ring see page K 3/2

DISMANTLING INSTRUCTIONS:

Loosen and remove lock ring bolts

Twist and withdraw the pipe

TENSILE TEST:

The following maximum tensile loads have been established

Test data: Hawle test laboratory tensile testing machine

HDPE-Pipe (PE 80) DIN 8074 - EN 12201 | PN 10

Data established by use of a support liner and under 0 bar internal pressure
Room temperature: 23 °C

Speed of tensile test (mm/min.): 0.1 x the free pipe length (L)

The table shows the maximum end load capacity of a System 2000 connection, compared with the effective theoretical loads in a PE pipeline with 10 bar

A System 2000 connection provides a safety factor of **4 to 6 times!**

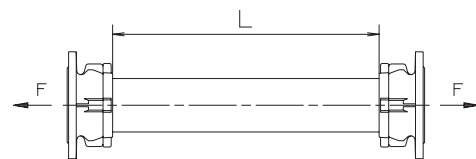
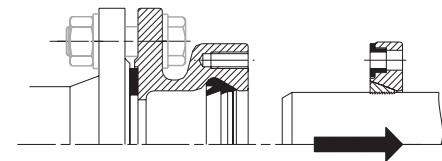
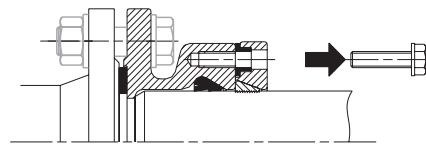
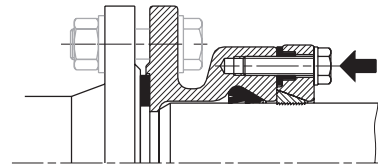
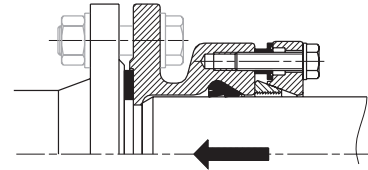
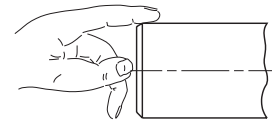
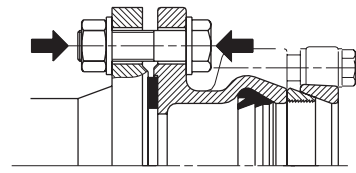

Ø pipe	Theoretical tensile load - (kN*) at 10 bar internal pressure	Max. tensile load (kN*) established in tests
63	3,15	20
75	4,42	28
90	6,37	38
110	9,50	56
125	12,27	63
140	15,40	66
160	20,10	98
180	25,45	130
200	31,40	145
225	39,80	153
250	49,10	233
280	61,60	215
315	77,80	270

*1 kN = 100 kp

Flange connections

Restraint

Design features

- For PE pipes according to EN 12201, DIN 8074
- Flanges sized in accordance with EN 1092-2, drilled according to EN 1092-2 | PN 10 standard; EN 1092-2 | PN 16 DN 200 please specify on order - other standards on request

Material | Technical features

- **Seals** made of elastomer
- **All cast iron parts** made of ductile iron, epoxy powder coated
- Max. operating pressure MOP (PN) 16

Application example

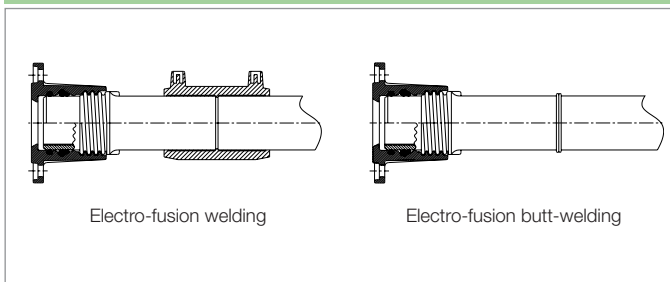

Flange adapter with PE fusion tail

No. 0310

PE 100-RC / SDR 11 - PN 16

No. 0311

PE 100-RC / SDR 17 - PN 10
(PE 100-RC / SDR 17,6 - PN 10 on request)

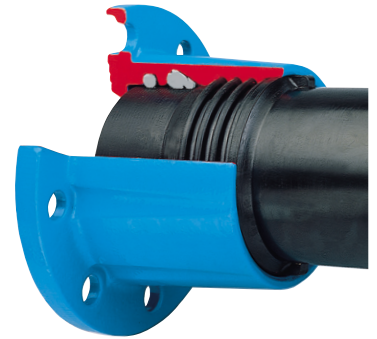
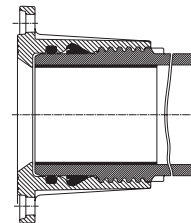

Order No.	Version	MOP (PN)	Flange DN / Ø Pipe								
			50 63	80 90	100 110	100 125	150 160	150 180	200 200	200 225	
0310	Flange with PE	16									
0311	fusion tail	10									

Design features

- For PE pipes according to EN 12201, DIN 8074
- Flange sized and drilled according to EN 1092-2 | PN 16 other standards on request
- Version for PVC pipes, restraint (with corundum grip ring) on request

Material | Technical features

- **Grip ring** made of POM
- **All cast iron parts** made of ductile iron, epoxy powder coated
- Max. operating pressure MOP (PN) 16

ISO pipe flange adapter

No. 5500

equal

No. 5530

reducing

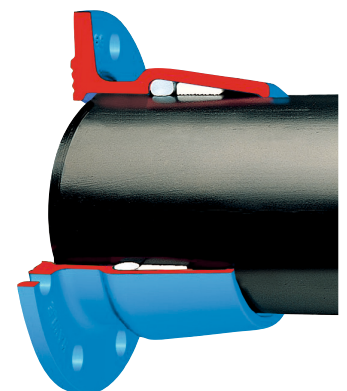
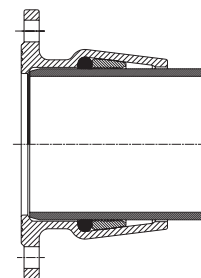

Order No.	Version	MOP (PN)	Flange DN / Ø Pipe															
			40 32	40 40	40 50	50 50	50 63	60 63	60 75	65 63	65 75	80 75	80 90	100 90	100 110			
5500	ISO pipe flange, equal	16																
5530	ISO pipe flange, reducing	16																

Flange connections

Restraint

Design features

- For PVC pipes according to EN ISO 1452-2
- Flange sized in accordance with EN 1092-2, drilled according to EN 1092-2 | PN 10 standard; EN 1092-2 | PN 16 DN 200 to DN 400 please specify on order - other standards on request

Material | Technical features

- **Seals** made of elastomer
- **All cast iron parts** made of ductile iron, epoxy powder coated
- Max. operating pressure MOP (PN) 16

Double chamber flange adapter No. 5600

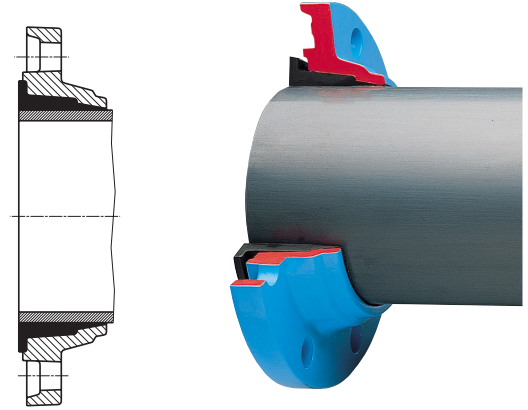

Order No.	MOP (PN)	Flange DN / Ø Pipe												
		50	60	65	80	100	125	125	150	200	200	250	300	400
		63	63	75	90	110	125	140	160	200	225	280	315	400
5600	16									*1	*	*1	*	*

Explanation:

* also available in PN 16

¹ Flange with an extended hole circle are not suitable for use with fixed studs!

Hawle-Vario

The innovative flexible fitting, PN 10 | PN 16



Design features

- Hawle VARIO is a flanged, telescopic fitting with integrated ball- and socket joint, permitting bending to all sides up to an angular deflection of 10 degrees
- Flange sized in accordance with EN 1092-2, drilled according to EN 1092-2 | PN 10 standard; EN 1092-2 | PN 16 DN 200 please specify on order - other standards on request
- Hawle-VARIO will be fixed in the installed position by means of a tension lock assembly
- Combines the function of an FF-piece, an adjustable elbow piece and a fitting and extension piece
- Hawle-VARIO saves time and has numerous application possibilities

Material | Technical features

- **All cast iron parts** made of ductile iron, epoxy powder coated
- **Locking ring, bolts, nuts** and **washers** made of stainless steel
- **O-rings** made of elastomer
- **Tension lock** made of stainless steel

No. 8010S

No. 8011S

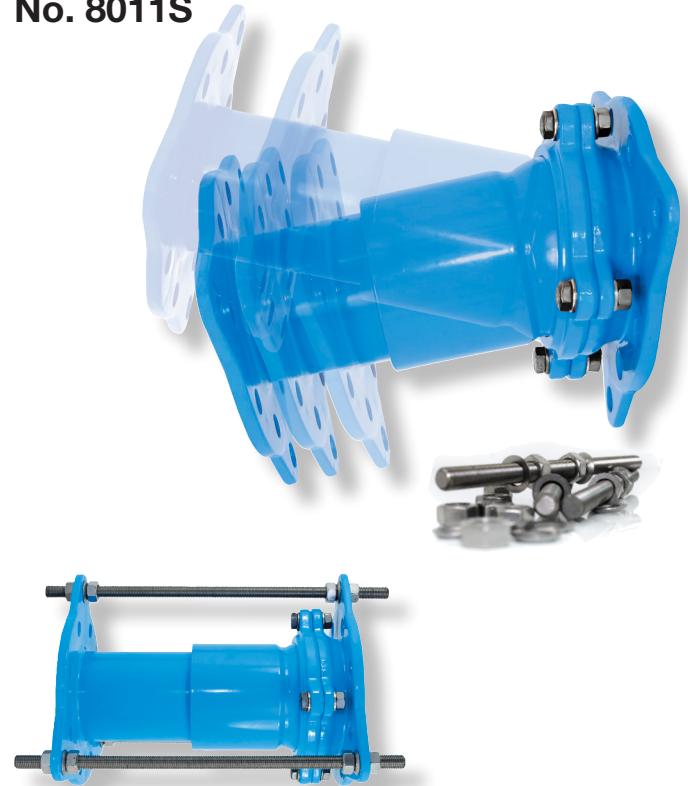

Order No.	Set-version	MOP (PN)	Dimensions/DN				
			50	80	100	150	200
8010S	short	16					
8011S	long						

Application example



Hawle-Vario

the innovative flexible fitting, PN 10 | PN 16

No. 8010S Short version, with tension lock

No. 8011S Long version, with tension lock

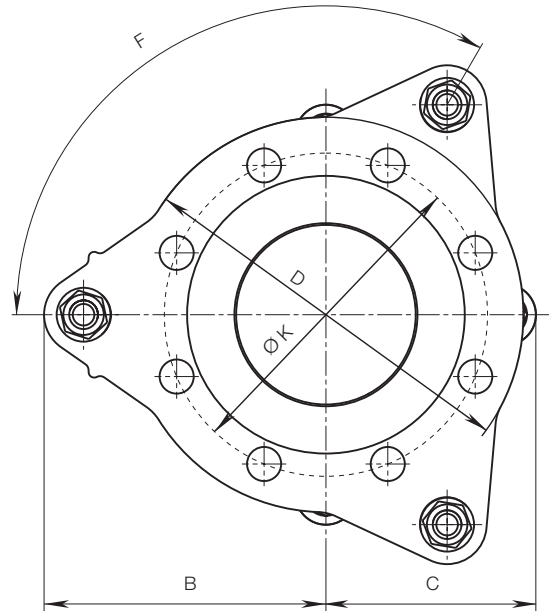
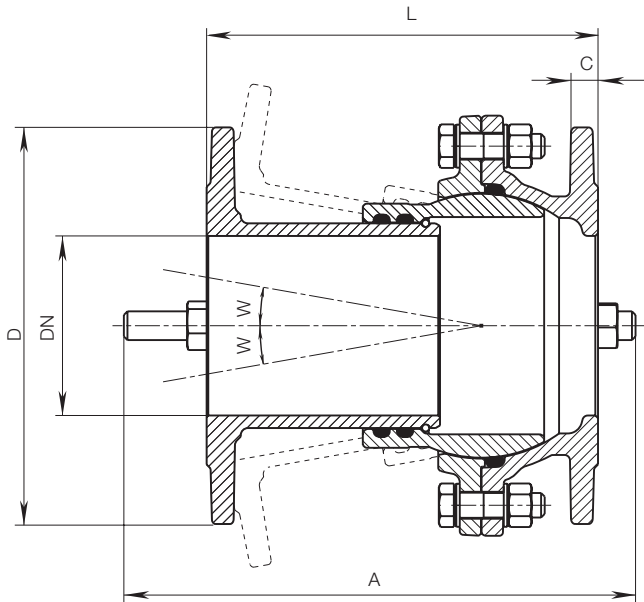

DN	MOP (PN)	Version	Adjustment range L	A	B	C	D	F	C	ØK	Angle W	Weight
50		short	150 – 207	285	130	87	165	3 x 120°	16	125	0 – 10°	8,90
		long	207 – 323	415								11,80
80	16	short	150 – 214	285	147	107	200	3 x 120°	16	160	0 – 10°	14,30
		long	214 – 344	415								16,85
100		short	150 – 216	285	157	117	220	3 x 120°	16	180	0 – 10°	16,20
		long	216 – 350	415								18,90
150		short	175 – 250	330	190	190	285	4 x 90°	18	240	0 – 10°	27,00
		long	250 – 408	480								29,30
200	10/16	short	195 – 292	360	229	229	340	4 x 90°	20	297	0 – 8°	44,80
		long	280 – 462	530								52,20

Flanged Fittings

Design features

- According to EN 545
- Max. operating pressure MOP (PN) 16
- Made of ductile iron, epoxy powder coated
- Flange size according to EN 1092-2 | PN 16
- Standard drilling to EN 1092-2 | PN 10

DN

50 – 300

Design features

- According to EN 545
- Max. operating pressure MOP (PN) 16
- Made of ductile iron, epoxy powder coated
- Flange size according to EN 1092-2 | PN 16
- Standard drilling to EN 1092-2 | PN 10

DN

50 – 500

Design features

- According to EN 545
- Max. operating pressure MOP (PN) 16
- Made of ductile iron, epoxy powder coated
- Flange size according to EN 1092-2 | PN 16
- Standard drilling to EN 1092-2 | PN 10

DN

50 – 400

Double flanged pipe

FF-piece

No. 8500



Double flanged taper

FFR-piece

No. 8550



Double flanged elbows 45°

FFK-piece 45°

No. 8540



Flanged Fittings

Design features

- According to EN 545
- Max. operating pressure MOP (PN) 16
- Made of ductile iron, epoxy powder coated
- Flange size according to EN 1092-2 | PN 16
- Standard drilling to EN 1092-2 | PN 10

DN

50 — 500

Design features

- According to EN 545
- Max. operating pressure MOP (PN) 16
- Made of ductile iron, epoxy powder coated
- Flange size according to EN 1092-2 | PN 16
- Standard drilling to EN 1092-2 | PN 10

DN

50 — 500

Double flanged elbows 90° 90° Q-piece

No. 8530

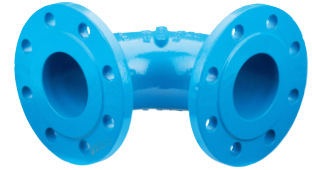

All flanged tee T-piece

No. 8510

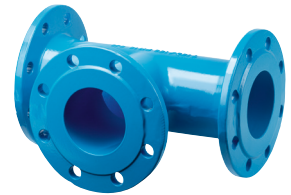

Flanged Fittings

Design features

- Max. operating pressure MOP (PN) 16
- Made of ductile iron, epoxy powder coated
- Flange size according to EN 1092-2 | PN 16
- Standard drilling to EN 1092-2 | PN 10

DN

80 – 150

Flanged Y piece No. 8754



Application example

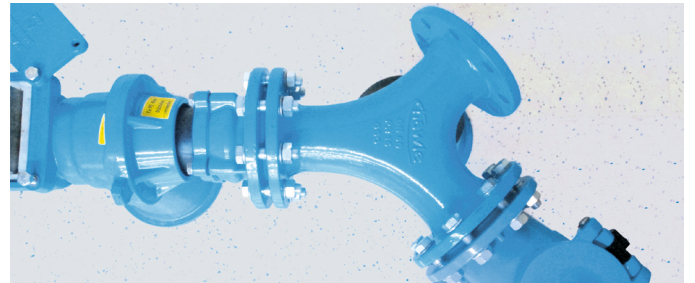

Design features

- Max. operating pressure MOP (PN) 16
- Made of ductile iron, epoxy powder coated
- With external thread 2" according to EN 10226-1
- With internal thread according to ISO 228

Ø Thread

2" – 2"

Y piece with 1 external thread and 2 internal threads

No. 2320



Notes

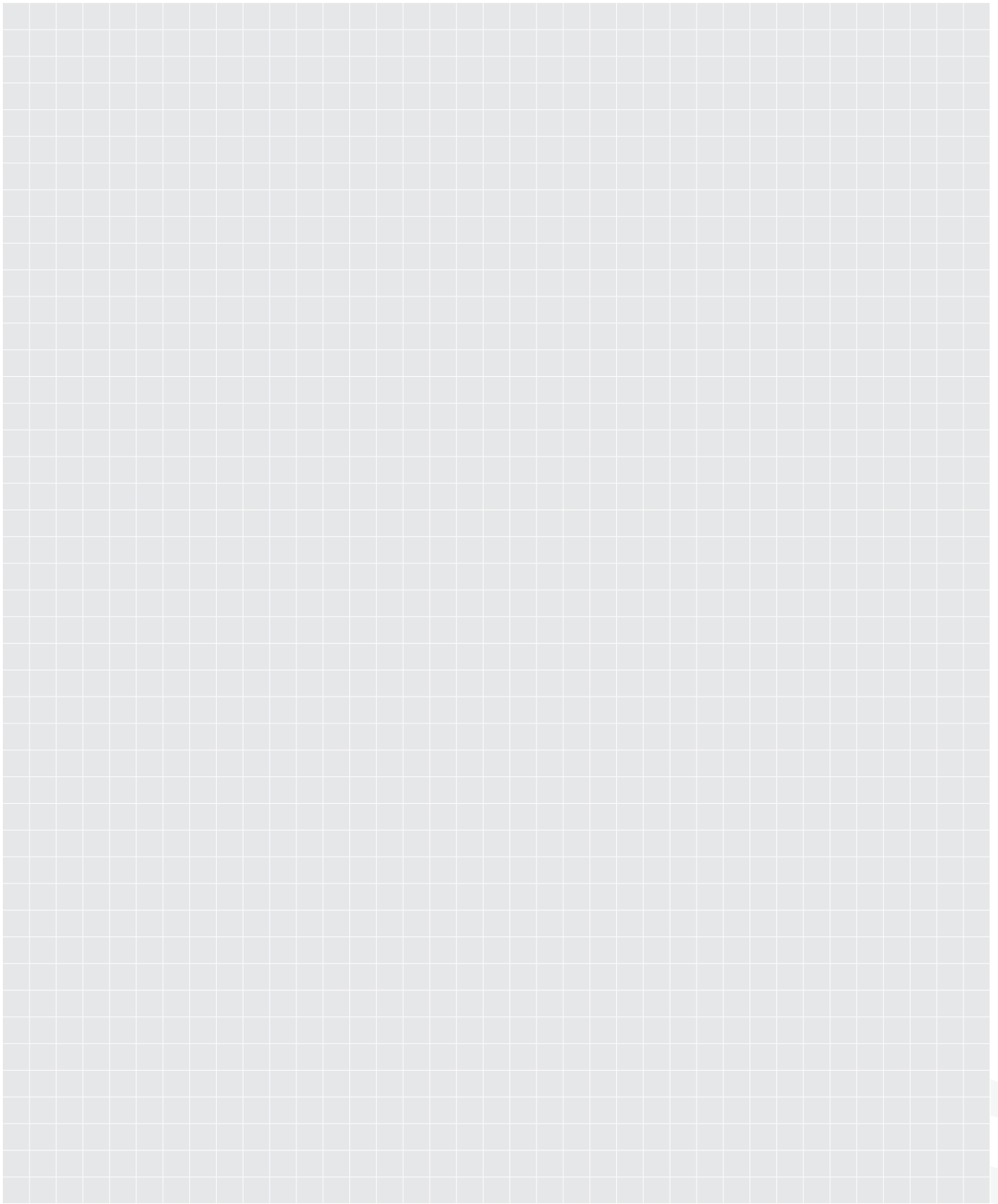

Ball Check Valve

Design features

- Prevents return flow through ball check principle
- Simple assembly and disassembly through single-sided loose flange with integrated flange gasket
- Drain opening in body
- Hinged lid with joint function for easy maintenance
- 100% corrosion protection
- Free passage
- Patent pending
- Face-to-face length according to EN 558 GR 48
- Flange sized in accordance with EN 1092-2, drilled according to EN 1092-2 | PN 10 standard; EN 1092-2 | PN 16 DN 200 – 300 please specify on order - other standards on request

Material | Technical features

- **Body** made of ductile iron, epoxy powder coated
- **Bolts** and **washers** made of stainless steel
- **Ball** made of elastomer with metal core
- Max. operating pressure MOP (PN) 16

Special versions

Optional drainage opening also in cover

No. 9841

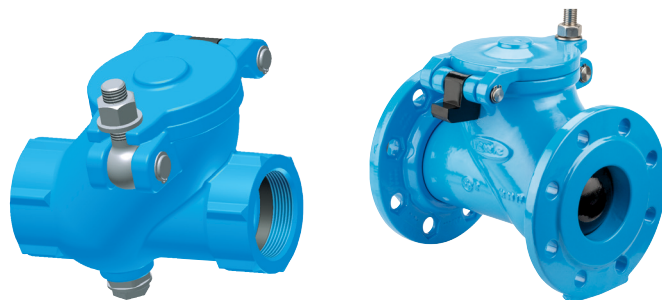

Application example

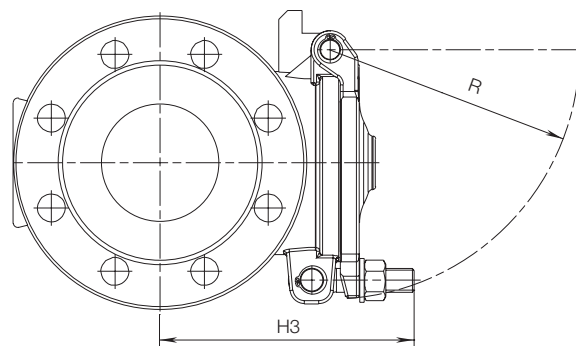
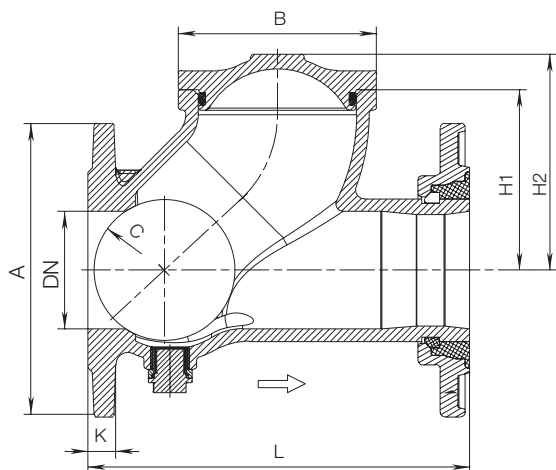

DN	MOP (PN)	A	B	Ø C	H1	H2	H3	K	L	R	Weight
2"	16	151	100	62	86	103	127	27	175	135	6
50		165	100	62	86	103	130	19	200	135	9
65		185	118	79	105	126	151	19	240	157	12
80		200	135	96	123	147	165	19	260	169	15
100		220	165	122	155	186	205	19	300	205	21
150		285	231	178	225	272	300	19	400	272	47
200		340	306	247	315	371	395	20	500	343	87
250		400	370	307	380	450	450	22	600	423	145
300		455	390	362	435	530	505	25	700	465	215

Check valves

Without lever and counterweight, PN 10 | PN 16

Design features

No. 9831

- Reliable prevention of medium back flow by automatic mechanical closing of the non-return valve
- The disc opens automatically, if the medium flows in the direction indicated by the arrow on the valve body
- Face-to-face dimensions according to EN 558 GR 48
- Flanges sized in accordance with EN 1092-2, drilled according to EN 1092-2 | PN 10 standard; EN 1092-2 | PN 16 DN 200 Please specify on order; other standards on request
- Reduced weight, simple cleaning, fully corrosion free, optimised velocity, simple maintenance
- Min. opening pressure 0,03 bar
- Min. closing pressure 0,5 bar (tight)



Material | Technical features

- **Body** made of ductile iron, epoxy powder coated
- **Disc** and **disc lever** made of elastomer/polyamide
- **Bolts** and **nuts** made of stainless steel
- **Disc gasket** made of elastomer
- **Shaft** made of polyamide

Installation advice

- In general non-return valves are designed to be installed in horizontal pipe lines. An installation in sloping and vertical pipe lines is possible if the flow of the medium is upwards
- Direction of flow has to be according to the arrow indicated on the body. Axle of the disc shaft has to be fully horizontal

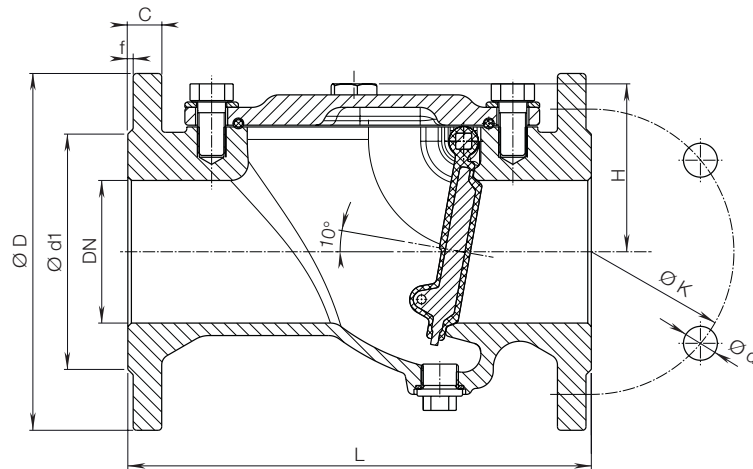

DN	MOP (PN)	L	H	ØD	Ød1	ØK	Ød	f	C	Bolts		Kv m³/h	Weight
										Qty.	Ød2		
50	16	200	77	165	102	125	19	3	19	4	16	170	9,5
80		260	95	200	138	160	19	3	19	8	16	366	14,5
100		300	113	220	158	180	19	3	19	8	16	698	22,0
150		400	155	285	212	240	23	3	19	8	20	1489	45,0
200	10	500	187	340	268	295	23	3	20	8	20	1388	82,0
	12									20			

HAKU - Saddle

With 45° ZAK 69 connector, for PE and PVC pipes



Design features

- For drilling of PE/PVC pipelines
- Half shells are calibrated to the external pipe diameter
- Reliable sealing by double O-ring profile seal

Material | Technical features

- **Body** made of ductile iron, epoxy powder coated
- **Seal** made of elastomer
- Max. operating pressure MOP (PN) 16

Suitable accessories

Service valve ZAK 69:	No. 2616
Fitting ZAK 69:	No. 6160
ZAK adapter:	No. 5895
Drilling machine:	No. 5800

No. 5262

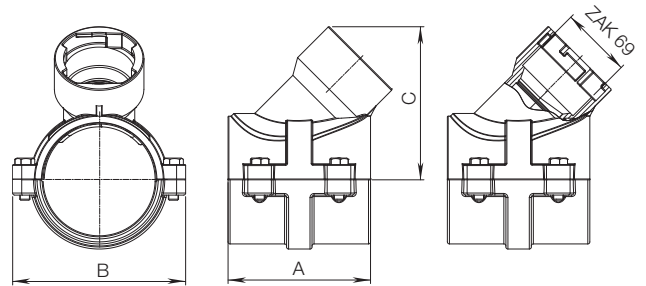

Application example



Pipe o. d. Ø	MOP (PN)	Max. drill	Connection	A	B	C	Weight
63	16	40	ZAK 69	100	125	140	3,20
75		40		130	135	150	3,70
90		50		140	150	150	4,10
110		50		140	170	150	4,20
140		50		140	204	175	5,60
160		50		140	230	190	6,40
225		50		140	300	220	10,00

Haku Pipe Saddle

With flanged outlet for PE and PVC pipes

Design features

- For **PE pipes** according to EN 12201 and DIN 8074 (**SDR 7,4 and SDR 11**) for **PVC pipes** according to EN ISO 1452-2 (**SDR 13,5 and SDR 21**)
- Solid construction of ductile iron epoxy powder coated
- No deformation of the pipe
- The drilled hole is sealed by an O-ring inserted in the upper part of saddle
- The rubber linings are bonded to the lower part of saddle - this ensures positive positioning of saddle (only for d 110 to 315)
- For holes from d 355 to 630 pipes, special drilling machine is available from Hawle
- Flange sized and drilled according to EN 1092-2 | PN 16 other standards on request
- For PE pipes with protective layer, this must be removed prior to mounting the saddle

Material | Technical features

- **Saddle body** and **segments** made of ductile iron, epoxy powder coated
- **O-ring seal in the bonnet** made of elastomer
- **Rubber in the lower part** of the saddle made of elastomer
- **Bolts** and **washers** made of stainless steel
- **Nuts** (Molybdenum-coated) made of stainless steel

Suitable accessories

Drilling machine:

No. 5807

No. 5230



d 110-315

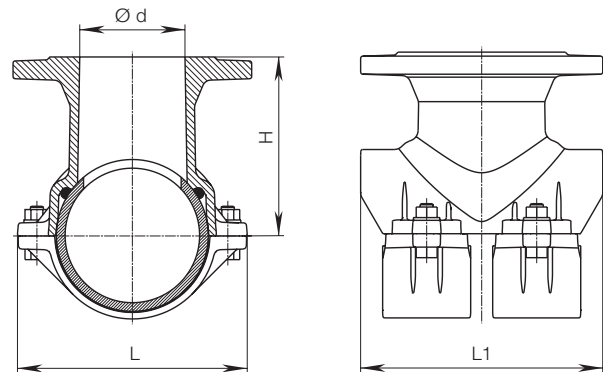

Order No.	Flange DN	MOP (PN)	Ø Pipe													
			110	140	160	180	200	225	250	280	315	355	450	500	630	
5230	80	16														
	100															
	150															

Ø Pipe	Flange DN	Ø d	H	L	L1	Weight
110	80	80	150	182	180	8,3
	100	80	166	212	220	11,8
140	80	100	166	212	220	13,3
	100	80	176	234	220	10,1
160	80	100	176	234	220	11,0
	100	80	186	254	220	11,2
180	80	100	186	254	220	12,2
	100	80	191	270	220	11,8
200	80	100	191	270	220	13,8
	100	80	206	301	220	14,0
225	80	100	206	301	220	16,0
	100	80	221	347	220	15,3
250	80	150	239	374	285	21,0
280	150	80	255	410	285	20,0
315	150	150	257	409	285	24,5
355	150	150	298	460	320	36,2
450	150	150	345	475	320	42,0
500	150	150	370	520	320	45,2
630	150	150	435	649	320	50,2

Haku - Saddle

With ZAK socket for PE and PVC pipes



Design features

- For PE and PVC pipes
- For drilling without pressure

Material | Technical features

- **Body** made of ductile iron, epoxy powder coated
- **Seal** made of elastomer
- Max. operating pressure MOP (PN) 16

Suitable accessories

Fittings see chapter J

Drilling machine:

No. 5800

Ø Pipe		H	L	L1	Weight
63	ZAK 46	46	135	100	1,90
90			150	110	3,00
110			170	120	3,10
125		39	190	120	3,80
140			205	120	4,80
160			230	120	5,00
225	39	310	180	9,70	

ZAK 46, max. drilling Ø 35 mm

ZAK-HAKU pipe saddle No. 5260

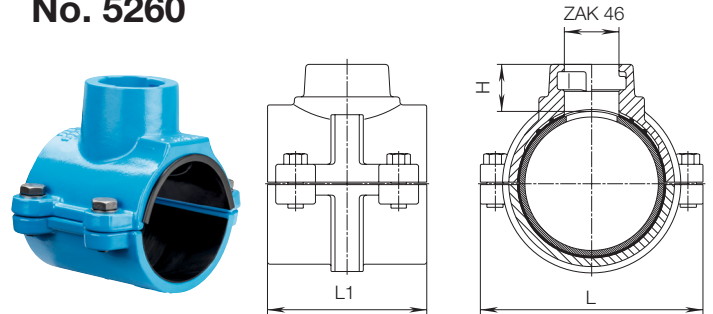

Order No.	MOP (PN)	Version	Ø Pipe							
			63	90	110	125	140	160	225	
5260	16	ZAK 46								

Design features

- For PE and PVC pipes
- For drilling under pressure

Material | Technical features

- **Body** made of ductile iron, epoxy powder coated
- **Seal** made of elastomer
- Max. operating pressure MOP (PN) 16

Suitable accessories

Fittings see chapter J

Drilling machine:

No. 5800

Saddle blade:

No. 8401

Ø Pipe		H	L	L1	Weight
90	ZAK 46	72	150	110	3,55
110		74	170	120	4,00
125		76,5	192	120	4,90
140		79	208	120	5,20
160		74	230	120	5,20
180		81	262	120	6,55
200		83	285	120	5,95
225		86	310	120	7,70
250		84	350	180	13,20
280		84	380	180	13,50

ZAK 46, max. drilling Ø 35 mm

ZAK-HAKU shut-off saddle No. 5320

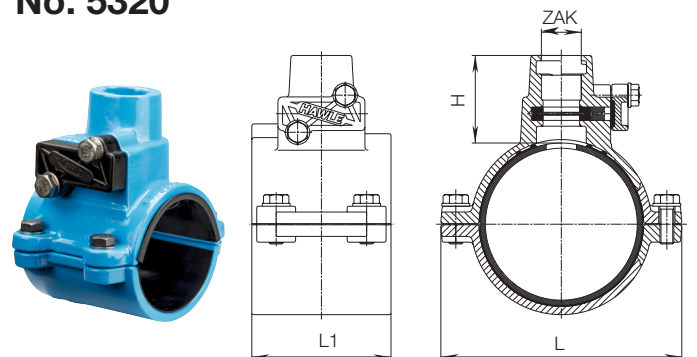

Order No.	MOP (PN)	Version	Ø Pipe											
			90	110	125	140	160	180	200	225	250	280		
5320	16	ZAK 46												

Haku - Saddle

With internal thread for PE and PVC pipes

Design features

- For **PE pipes** according to EN 12201 and DIN 8074 and **PVC pipes** according to EN ISO 1452-2
- The HAKU seal is in full contact with the entire diameter of the PE or PVC pipe and is glued onto the saddle for ease of assembly
- Several concentric seals with increasing diameter surround the outlet, relieving pressure exerted upon the drill hole and protects it from deformation
- The protective layer on PE pipes should be removed prior to mounting the saddle

Material | Technical features

- **Saddle body** made of ductile iron, epoxy powder coated
- **Seals** made of elastomer
- **Bolts** (Molybdenum-coated) and **washers** made of stainless steel
- **Corrosion protection ring** made of elastomer
- Max. operating pressure MOP (PN) 16

Suitable accessories

Fittings see chapter J

Drilling machine:

No. 5800

No. 5250



Order No.	Pipe Ø	MOP (PN)	Internal thread outlet ISO 228	
			1½"	2"
5250	63	16		
	75			
	90			
	110			
	125			
	140			
	160			
	180			
	200			
	225			
	250			
	280			
	315			

Ø Pipe	G ISO 228	Ø d	H	L	L 1	Weight
63	1½"	40+	62	124	100	1,90
	2"	40+	68			2,10
75	1½"	40	68	135	110	2,20
	2"	50	73			2,30
90	1½"	40	75	150	110	2,60
	2"	50	80			2,70
110	1½"	40	85	170	120	3,80
	2"	50	90			3,60
125	1½"	40	93	192	120	4,15
	2"	50	98			4,10
140	1½"	40	100	208	120	4,60
	2"	50	106			4,50
160	1½"	40	111	230	120	6,30
	2"	50	116			6,20
180	1½"	40	127	262	120	8,10
	2"	50	127			8,10
200	1½"	40	137	282	120	8,30
	2"	50	137			8,10
225	1½"	40	145	310	120	9,70
	2"	50	150			9,60
250	1½"	40	163	347	180	11,50
	2"	50	163			12,00
280	2"	51	178	377	180	14,20
315	2"	51	196	408	180	16,70

+ Drilling max. 35

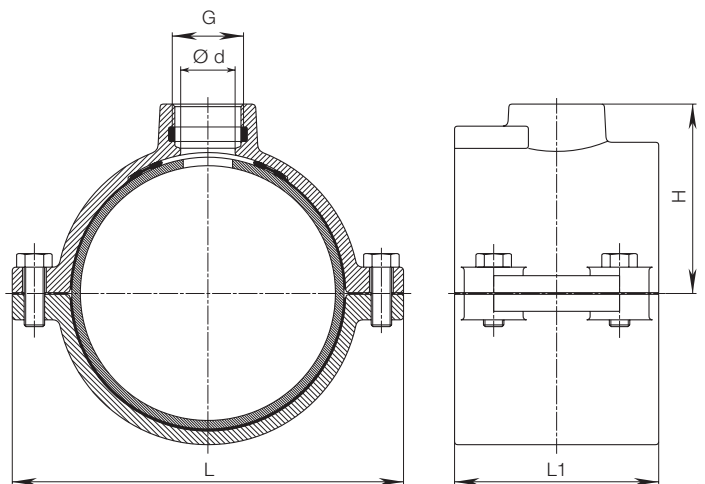

Haku Shut-off Saddle

With internal thread for PE and PVC pipes



Design features

- For **PE pipes** according to EN 12201 and DIN 8074 and **PVC pipes** according to EN ISO 1452-2
- For under pressure drilling
- Can be pressure tested from both directions
- The HAKU seal is in full contact with the entire diameter of the PE or PVC pipe and is glued into the saddle for ease of assembly
- In addition several concentric seals with increasing diameter surround the outlet thus relieving the pressure upon the drill hole and protecting it from deformation
- For PE pipes with protective layer, this must be removed prior to mounting the saddle

No. 5310



Material | Technical features

- **Saddle body** made of ductile iron, epoxy powder coated
- **Seal** made of elastomer
- **Bolts** (Molybdenum-coated) and **washers** made of stainless steel
- **Seal cover** made of POM, with rubber seal, glass fiber reinforced
- **Bolts** and **washers** made of stainless steel
- **Corrosion protection ring** made of elastomer
- Max. operating pressure MOP (PN) 16

Suitable accessories

Fittings see chapter J

Drilling machine:

No. 5800

Saddle blade:

No. 8401

Order No.	Pipe Ø	MOP (PN)	Internal thread outlet ISO 228	
			1½"	2"
5310	75	16		
	90			
	110			
	160			

ØPipe	G ISO 228	Ød	H	L	L1	Weight
75	1½"	43	91	135	110	3,3
	2"	43	95			3,0
90	1½"	43	101	150	110	3,6
	2"	43	105			3,4
110	1½"	43	113	170	120	4,3
	2"	43	117			4,0
160	1½"	43	140	230	120	5,6
	2"	43	145			5,6

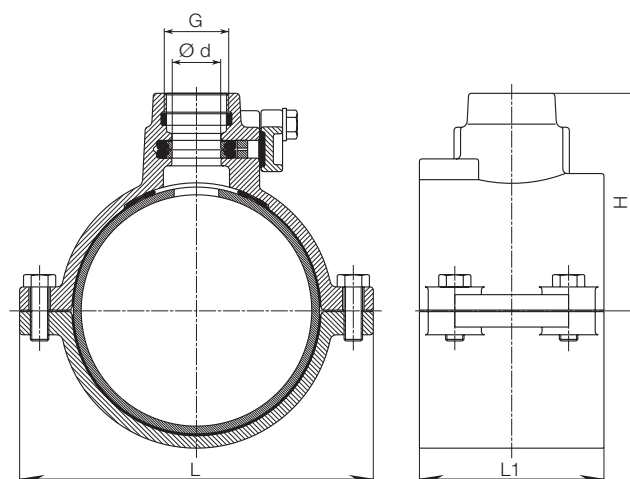

Universal Shut-off Saddle

With flanged outlet

Design features

- For drilling of cast, steel and AZ pipes under pressure (nominal diameter DN 150-500)
- Shut-off through saddle blade
- Two straps and an additional saddle seal are always required!
- Max. drilling diameter: 75 mm

Material | Technical features

- **Body** made of ductile iron, epoxy powder coated
- **Seal** made of elastomer
- Flange sized and drilled according to EN 1092-2 | PN 16 other standards on request
- Max. operating pressure MOP (PN) 16

Suitable accessories

Strap:	No. 3110
Saddle seal:	No. ND82
Saddle blade:	No. 8401
Drilling machines:	No. 5807

No. 3820



Flange DN	MOP (PN)	A	B	C	Weight
80	16	200	185	245	14,00

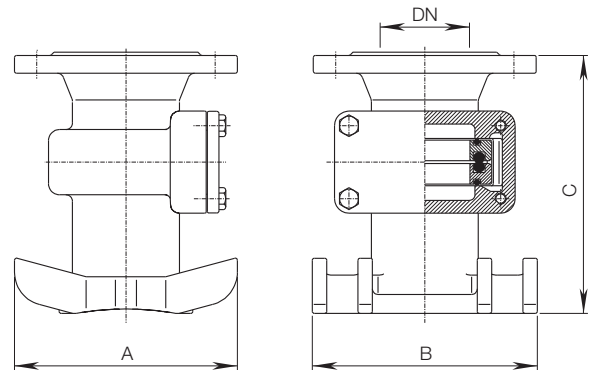

Application example

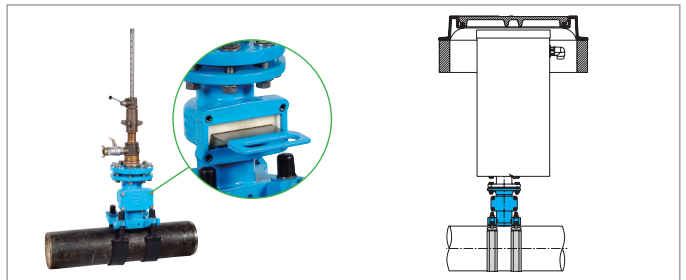

With drilling device and X flange

The illustration shows the Universal shut-off saddle, mounted on a pipeline with two straps and attached automatic air valve assembly!

Design features

- Strap for universal shut-off saddle No. 3820 and universal pipe saddle with integrated flanged knife gate valve No. 4807
- For the nominal diameter DN 65 to DN 500 (max. Ø 535 mm) - Special lengths on request!
- Particularly wide version of 65 mm, thereby lowest surface pressure on pipe - standard version for all pipe types
- Tightening torque: min. 60 Nm / max. 80 Nm

Material | Technical features

- **Threaded bolts** made of stainless steel
- **Nuts** made of stainless steel
- **Clamping jaws** made of glass fibre reinforced polyamide
- **Bracket plate** made of stainless steel incl. rubber strap insulation

Pipe exterior Ø	Cast pipe - DN	Weight
75-83	65	0,73
98-105	80	0,69
112-122	100	0,79
139-149	125	0,81
166-177	150	0,88
216-227	200	1,01
268-280	250	1,17
323-330	300	1,36

Strap No. 3110



Design features

- Strap for universal shut-off saddle No. 3820 and universal pipe saddle with integrated flanged knife gate valve No. 4807
- For cast, steel and AZ pipes
- Two straps are always required
- Max. drilling diameter: 70 mm
- The saddle seal is equivalent to the corresponding pipe diameter of the pipe saddle and ensures error-free sealing function

Material | Technical features

- **Material** made of elastomer

Pipe DN	Weight
125 - 150	0,050
200 - 300	0,050
350 - 500	0,064

Saddle seal No. ND82



Pipe repair clamp

For steel, ductile iron, asbestos cement and PVC-pipes

Design features

- The clamp with the self-centering lug system
- Fully encompassing gasket seals complete gaps and other pipe damage
- The bolts (3) are welded to the bolt bar (4). Squeezing the handle makes for easy assembly onto the pipe. The nuts are fed directly to the bolts from a special nut dispenser (8). This eases the positioning of the lugs and bolts and avoids handling of loose parts.
- Special version such as larger diameters and other lengths on request
- **No. 0750** tested with new pipes in delivery condition
 - Ø 54 - Ø 190 PN 16
 - Ø 190 - Ø 430 PN 10
- **No. 0751** tested with new pipes in delivery condition
 - Ø 87 - Ø 186 PN 16
 - Ø 208 - Ø 430 PN 10
 - Ø 425 - Ø 471 PN 6
 - Ø 472 - Ø 550 PN 5

Material | Technical features

- Band** made of stainless steel
- Lug** made of stainless steel
- Bolts** made of stainless steel
- Bolt-bar** made of stainless steel
- Bridging plate** made of stainless steel
- Gasket** made of elastomer
- Handle** made of stainless steel
- Nut dispenser** made of elastomer (from 3 bolts)

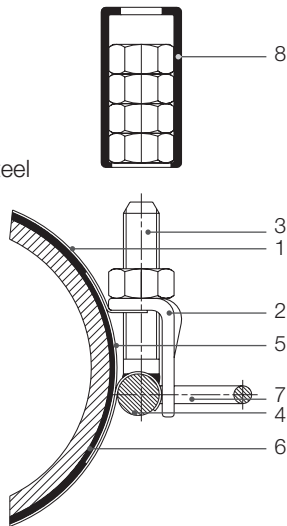

Design features

- For steel, ductile iron and AC pipes
- For pipe diameters from 21 - 64, length 76

Material | Technical features

- Band** made of stainless steel
- Gasket** made of elastomer
- Lug** bridge of galvanised iron
- Bolts** galvanised
- Nuts** galvanised
- Washers** made of stainless steel

No. 0750 "single lug"

Pipe diameter 54-430, length 150-380

No. 0751 "double lug"

Pipe diameter 87-471, length 200-380

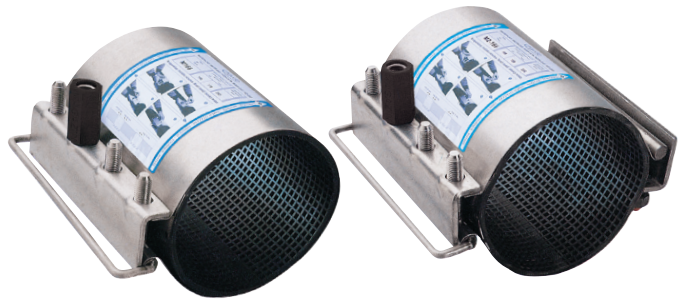

Quick assembly with H-Nut dispenser which prevents loss of nuts into the dirty trench.

Application examples

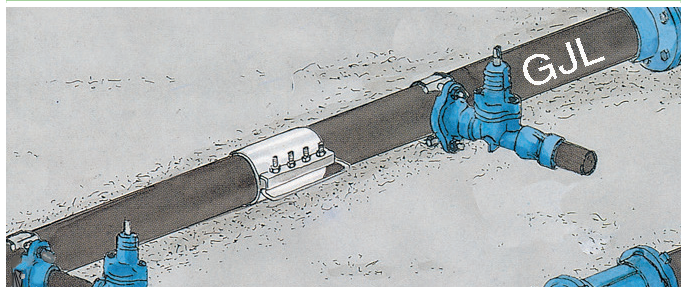

No. 0501 "single lug"

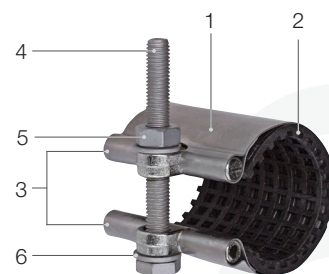

Pipe repair clamp

For steel, cast iron, AC and PVC pipes



No. 0750 single lug

Type	ØPipe	Length	Suitable for pipe DN						PVC ext. Ø	Weight
			Steel	Cast iron	AC-PN 10		AC-PN 16			
					raw	turned	raw	turned		
K 54	54 – 58	150	50						1,1	
M 54		200							1,5	
K 58	58 – 64	150	50						1,1	
M 58		200							1,5	
K 63	63 – 68	150							1,2	
M 63		200		50					1,6	
K 68	68 – 76	150				50	50		1,2	
M 68		200							1,7	
K 75	75 – 83	150	65	60	60	60	60		1,3	
M 75		200							1,7	
K 82	82 – 91	150	80	65					1,3	
M 82		200							1,8	
K 95	95 – 104	150		80	80	80		80	1,4	
M 95		200							1,9	
K 104	104 – 112	150	100				80	80	1,5	
M 104		200							2,0	
K 112	112 – 121	150	100	100		100			1,5	
M 112		200							2,1	
K 115	115 – 125	150		100	100				1,5	
M 115		200							125	2,1
K 120	120 – 130	150				100	100		1,7	
M 120		200						100	125	2,2
K 131	131 – 141	200	125				100		3,2	
M 131		250							140	4,0
K 140	140 – 150	200							3,2	
M 140		250		125		125				4,0
L 140		315							5,2	
K 151	151 – 161	200	150						3,4	
M 151		250			125			125	160	4,3
L 151		315							5,4	
K 166	166 – 178	200	150	150					3,5	
M 166		250				150				4,4
L 166		315							5,5	
K 178	178 – 190	200				150	150		3,6	
M 178		250						150	180	4,5
L 178		315							5,7	
K 190	190 – 202	200							3,9	
M 190		250					150	150	200	4,7
L 190		315							5,8	
K 200	200 – 212	250	200						5,0	
M 200		315								6,2
L 200		380							7,5	
K 215	215 – 227	250	200	200					5,0	
M 215		315							225	6,3
L 215		380							7,6	
K 233	233 – 246	250							5,2	
M 233		315			200	200				6,3
L 233		380							7,8	
M 250	250 – 262	315					200	200	6,8	
L 250		380							250	8,1
K 269	269 – 281	250	250	250					5,6	
M 269		315							280	7,1
L 269		380							8,5	
M 285	285 – 297	315				250	250		7,5	
L 285		380								9,0
K 306	306 – 318	250							6,0	
M 306		315					250	250	315	7,8
L 306		380							9,2	
K 315	315 – 327	250	300	300					6,2	
M 315		315							315	7,8
L 315		380							9,5	
M 345	345 – 357	315	350			300	300		8,3	
L 345		380							355	10,0
M 366	366 – 379	315	350	350					8,7	
L 366		380					300	300		10,5
K 400	400 – 412	250	400						7,4	
M 400		315				350	350		400	9,2
L 400		380							10,9	
K 418	418 – 430	250	400	400					7,6	
M 418		315								9,7
L 418		380							11,8	

No. 0751 double lug

Type	ØPipe	Length	Suitable for pipe DN						PVC ext. Ø	Weight	
			Steel	Cast iron	AC-PN 10		AC-PN 16				
					raw	turned	raw	turned			
M 87	87 – 102	200	80	80	80	80			90	2,7	
M 106	106 – 124	200	100	100	100	100	80		110	2,8	
M 114	114 – 132	200	125	100	100	100		100	125	2,9	
K 132	132 – 152	200	125	125	125	125	125	100		140	4,9
M 132		250								160	6,2
K 142	142 – 162	200	150	125	125	125	125	125		160	5,0
M 142		250									6,4
K 160	160 – 180	200	150	150							5,3
M 160		250				150				160	6,5
L 160		315								8,1	
K 166	166 – 186	200	150	150							5,3
M 166		250				150	150				6,7
L 166		315								8,3	
K 208	208 – 230	250	200	200							7,2
M 208		315								225	8,8
L 208		380								10,7	
K 220	220 – 242	250									7,3
M 220		315			200		200			225	9,0
L 220		380								11,1	
K 236	236 – 258	250									7,5
M 236		315				200	200	200	200	250	9,4
L 236		380								11,1	
K 271	271 – 293	250	250	250	250	250	250				7,8
M 271		315								280	9,9
L 271		380								11,8	
M 306	306 – 328	315	300	300				250	250	315	10,0
L 306		380									
K 330	330 – 352	250					300				8,9
L 330		380									
M 346	346 – 368	380	350			300	300			355	13,3
L 346											
M 369	369 – 392	315									11,2
L 369		380			350			300	300		
M 406	406 – 430	315	400	400	350						11,7
L 406		380									
M 448	448 – 471	315			400	400			450	15,1	

No. 0750 / 0751 Special versions

Order No.	Version	Type	ØPipe	Length								
0750	single lug	S	50-550	150	200	250	315	380	510	640	835	1030
0751	double lug											

No. 0501 for steel, ductile iron and AC pipes

Type	ØPipe	Length	Weight
D 21	21 – 25	70	0,25
D 26	26 – 30	70	0,26
D 33	33 – 37	70	0,27
D 42	42 – 45	70	0,28
D 48	48 – 54	70	0,29
D 60	60 – 64	70	0,31

Service Valve

With knife gate and ISO-fitting for PE pipes

Design features

- The ideal gate valve for wastewater house connection lines
- Spindle lies outside the flow medium
- Reliable and leak-proof shut-off function by knife gate and O-ring seal
- Suitable for underground installation
- Double-sided restraint ISO-fitting connection for PE pipes
- Bonnet can be replaced „under pressure“

Material | Technical features

- **Body** made of ductile iron, epoxy powder coated
- **Spindle** and **knife gate** made of stainless steel
- **Grip ring:** PE pipe - POM (Standard)
PVC pipe - corundum PVC (aon request)
- Max. operating pressure MOP (PN) 10

Suitable accessories

Handwheel:		No. 7800
Extension spindles:	rigid	No. 9101
	telescopic	No. 9601

No. 2615



Pipe o. d. \varnothing	MOP (PN)	\varnothing min.	H	L	L1	VK	Weight
50	10	40	202	226	91	10,3	5,10
63		56	202	240	103	10,3	5,10

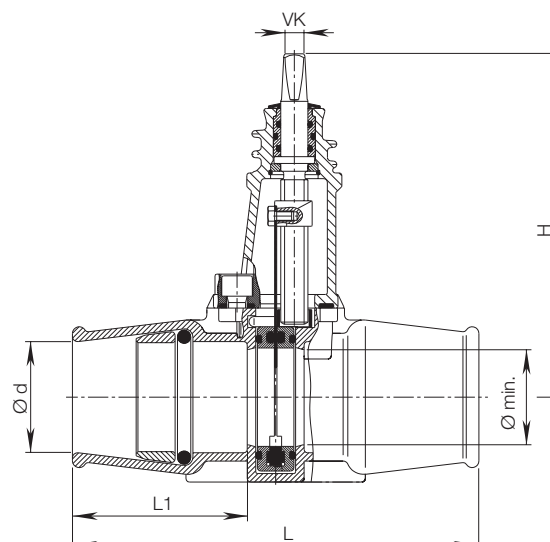

Application example

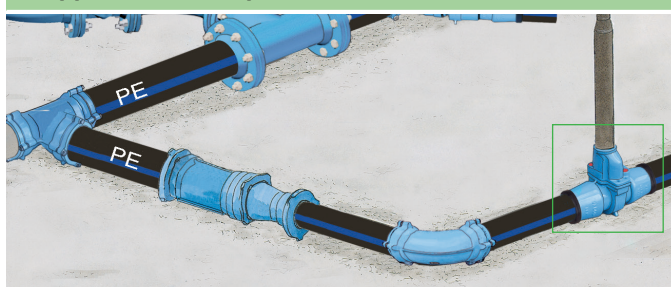

Service Valve

With knife gate and zak 69 socket and spigot



Design features

- Service valve for house connection lines with ZAK system
- Spindle lies outside the flow medium
- Reliable and leak-proof shut-off function by knife gate and O-ring seal
- Suitable for underground installation
- Bonnet can be replaced „under pressure“
- 100% corrosion protection
- Max. drilling diameter: 50 mm

Material | Technical features

- **Body** made of ductile iron, epoxy powder coated
- **Spindle** and **knife gate** made of stainless steel
- Sleeve/spigot: ZAK 69
- Max. operating pressure MOP (PN) 10

Suitable accessories

Handwheel: No. 7800
 Extension spindles: rigid No. 9101
 telescopic No. 9601
 Drilling set ZAK 69 and cup drill see chapter K

No. 2616



Spigot / Socket	MOP (PN)	H	L	VK	Weight
ZAK 69	10	203	146,5	10,3	4,40

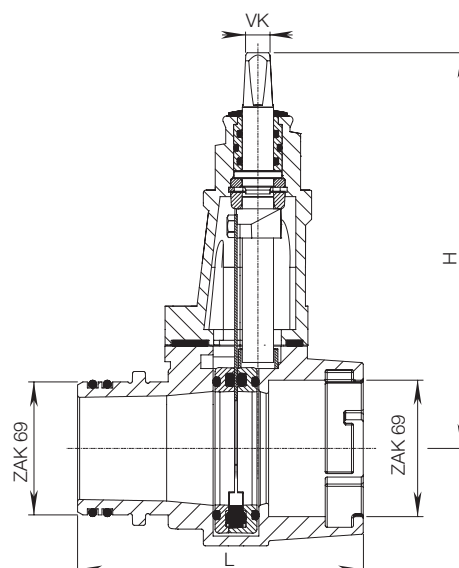

Application example



Service valve

Made of POM with Hawle-FIT sockets

Design features

- Resilient seated gate valve with smooth straight-through bore
- For PE pipes according to EN 12201 and DIN 8074 | up to PN 16; up to 30° C medium temperature
- The high-tensile connection to the pipe is achieved via the two Hawle-FIT sockets
- Assembly-ready supply: no screwing required before inserting the pipe
- All parts made of corrosion free materials
- Maximum spindle torque: 80 Nm
- Easy disassembly without special tools
- Sealing system: the contact between wedge and body is friction free. Therefore no scuffing or abrasion of the wedge
- Hawle FIT socket details see page J 1/1

Standard version: without handwheel and extension spindle

Special versions: on request

Material | Technical features

- 1 **Clamping nut** made of POM
- 2 **Lip seal** made of elastomer
- 3 **Grip ring** made of POM

Suitable accessories

Handwheel:		No. 7800
Extension spindles:	rigid	No. 9101
	telescopic	No. 9601
Support liners:		No. 6021
Hawle-FIT type for reducer:		No. 6640HFA

Design features

- For the reduction of Hawle-FIT socket

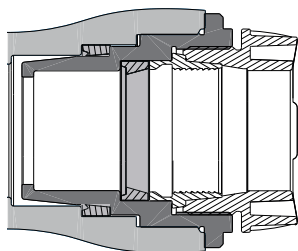

No. 2631

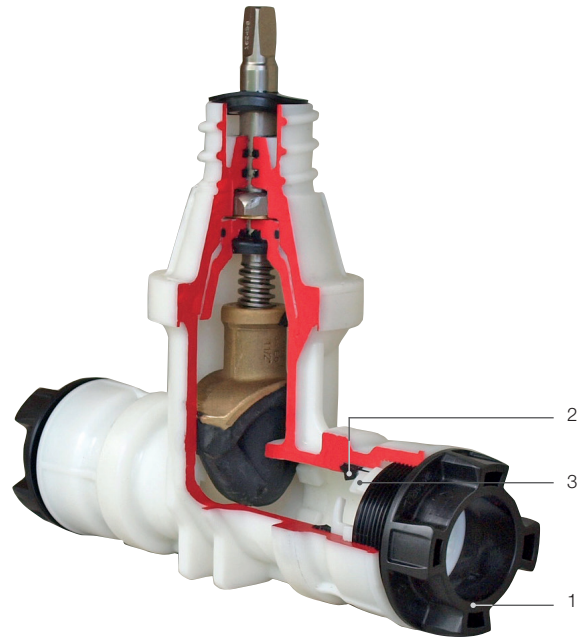

Order No.	Version	MOP (PN)	Dimensions/DN			
			1"	1¼"	1½"	2"
2631	With Hawle-FIT socket	16				

PE 80: SDR 7,4 - SDR 17,6

PE 100: SDR 11 - SDR 17

For PE 80 and PE 100: SDR 17,6 and 17 we recommend using a support liner

Hawle-FIT type for reducer No. 6640HFA



Order No.	Version	MOP (PN)	Dimensions/DN							
			32 25	40 25	40 32	50 32	50 40	63 40	63 50	
6640HFA	With Hawle-FIT socket	16								

Service valve

Made of POM with Hawle-FIT sockets



Service valve, POM

With dual Hawle-Fit connections sockets for PE-pipes

No. 2631

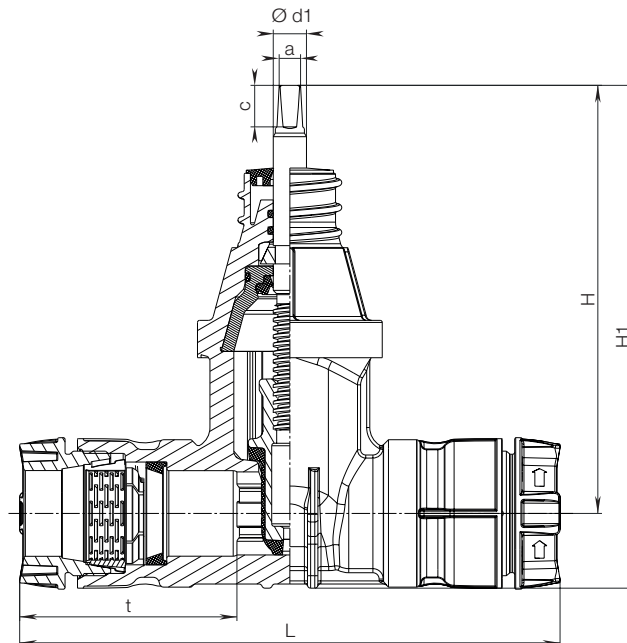

DN	Ø pipe ext.	Valve				Spindle			Weight
		t	L	H	H1	a	c	Ø d1	
1"	32	84	216	177	212	10,3	20	16	1,05
1¼"	40	105	260	205	241				1,56
1½"	50	116	294	205	247				1,83
2"	63	123	306	228	278				2,47

Benefits of the Hawle-FIT sockets

- Ready to install from packaging
- Can be mounted without previous chamfering of the pipe ends
- Low insertion forces
- Defined stop of the clamping nut made of POM for a secure connection
- Easy assembly and disassembly without special tools
(Clamping nut can be fixed with a standard commercially available pipe cutter)

Assembly instructions

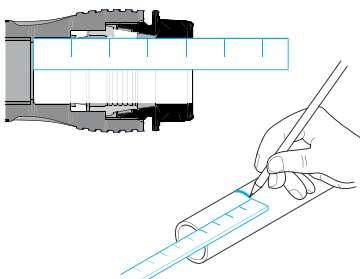

Measuring the insertion depth

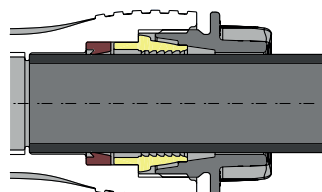

POM clamping nut open

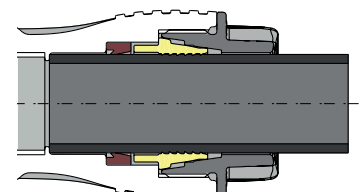

Pom clamping nut fully tightened

Flushing Valves

Design features

- Lockable flushing valve for easy flushing of culvert or offset canals
- No complex chamber construction necessary, thus no high running costs for the maintenance of the chambers
- No hazards due to traversing the chambers
- Simple flushing due to free passage
- Upper outlet with closable storz C outlet
- Lower outlet: flange, straight
- Optionally with 2" external thread
- Compact construction, low build costs as no chamber construction
- Special lengths and other versions on request

Material | Technical features

- **Body** made of ductile iron, epoxy powder coated
- **Seal** made of elastomer
- **Spindle** and **knife gate** made of stainless steel
- When open, knife gate is completely outside the medium (free passage)
- Flushing connection storz: C coupling (aluminium)
- With discharge on request

Suitable accessories

- Valve key No. 3420
- Standpipe for wastewater flushing valve No. 9857

Design features

- Special standpipe for fitting on flushing valves as an extension

Material | Technical features

- **Standpipe** and **angle** made of galvanised steel 2"
- **Storz C coupling** made of aluminium
- **Ball valve** made of nickel-plated brass 2"
- Max. operating pressure MOP (PN) 16

Application example

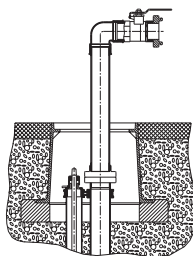

Flushing valve with straight flange outlet No. 9858

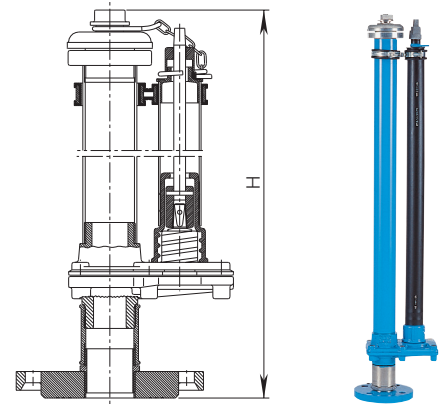

Order No.	Connection flange	H	RD*	Weight
9858	DN 50	800	1,00	13,70
		1050	1,25	14,90
		1300	1,50	16,10
		1800	2,00	17,90
	DN 80	800	1,00	14,50
		1050	1,25	16,50
		1300	1,50	17,90
		1800	2,00	20,90

RD* = pipe cover

Standpipe for wastewater flushing valve No. 9857

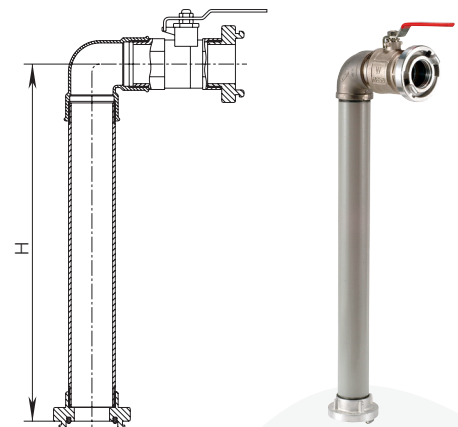

Order No.	MOP (PN)	H	Weight
9857	16	660	5,30

Hawle-Fit

Fittings for PE pipes



Design features

- For PE pipes according to EN 12201-2 and DIN 8074, up to PN16
- The new generation of fitting pipes Hawle-FIT has been designed to connect PE pipes with an outside diameter of d 25 to 63 and a working pressure of up to 16 bar
- The Hawle-FIT is designed for communal waste water applications within a temperature range of up to 30 °C
- Installation and dismantling is simply performed with no special tools required
- The service life of the Hawle-FIT is guaranteed by the use of high-quality polymer materials; the clamping nut as functional carrier is very stable through its unique construction
- The special clamp toothing (no continuous groove) reduces the impact force on the pipe. This significantly enhances the service life of the pipe
- The stainless steel reinforcing ring increases the strength of the fitting with internal thread outlets
- UV resistant



Material | Technical features

- **Body** made of high-quality polymer
- **Grip rings and clamping unit** made of POM
- **Seal** made of elastomer

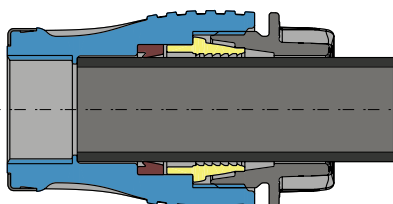

Open clamping nut

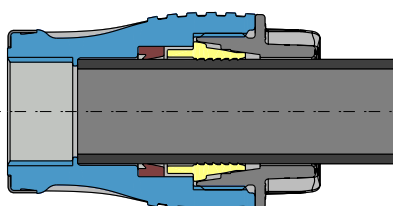

Clamping nut fully tightened

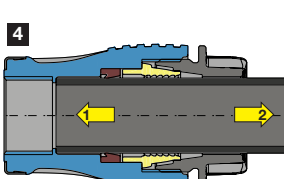
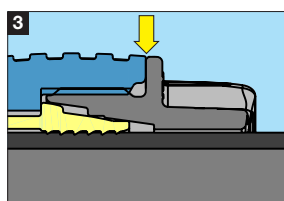
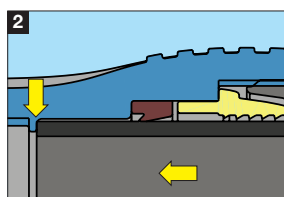

- The Hawle-FIT fitting is supplied ready for installation which means no turning of the screw is required before inserting the pipe! The fitting is unpacked and is then ready for use (ill. 1).
- The Hawle-FIT fitting can be assembled without any pipe chamfering. Push until reaching built-in end stops. This saves time and money (ill. 2/3).
- Prior to fastening the screw, the grip ring does not reveal any initial tension or teeth. For this reason only very low insertion forces are required
- The construction of the Hawle-FIT fitting amplifies the dismantling of the pipe since the fitting does not have to be completely dismantled. The clamping nut is loosened but not actually removed (ill. 4)

* PE 80: SDR 7,4 - SDR 17,6
 PE 100: SDR 11
 PE 100: SDR 17
 (support liner No. 6021 is required)

Hawle-Fit

Assembly and dismantling

- Instruction - Fittings / Valves
- For PE pipes \varnothing d 25 — d 63 up to PN 16

HAWLE-FIT ASSEMBLY INSTRUCTIONS

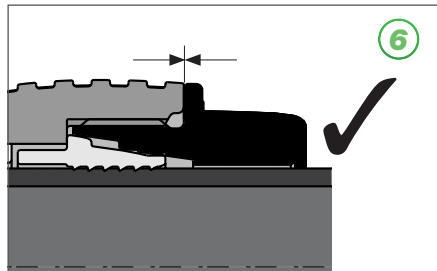
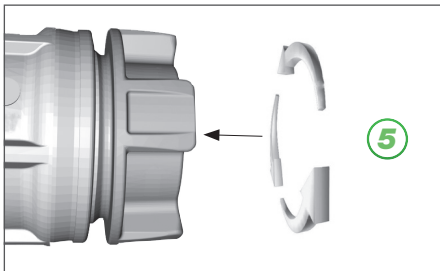
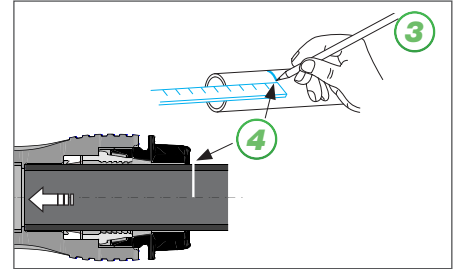
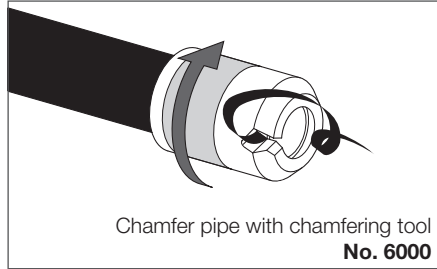
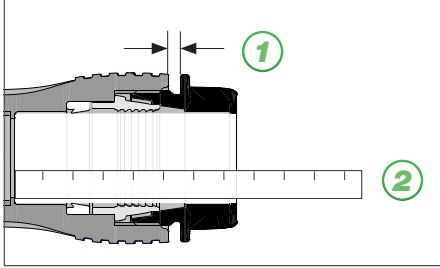

Low pressure conditions require a support liner No. 6021



For PE pipes SDR 17, is required a support liner No. 6021

HAWLE-FIT DISMANTLING

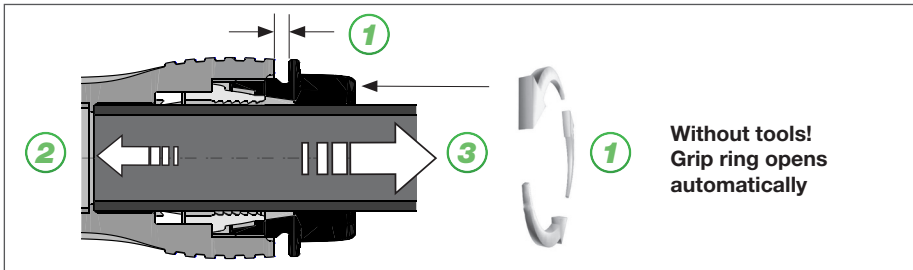

Hawle-Fit

Fittings for PE pipes



Design feature

- With external thread according to EN 10226-1

Order No.	Ø Pipe	Thread	MOP (PN)	L	E	Ø D	Weight
6120HFA	25	¾"	16	98	74	54	0,09
	32	1"		107	80	61	0,12
	40	1¼"		117	81	75	0,21
	50	1½"		133	103	90	0,31
	63	2"		149	115	105	0,45

With external thread No. 6120HFA

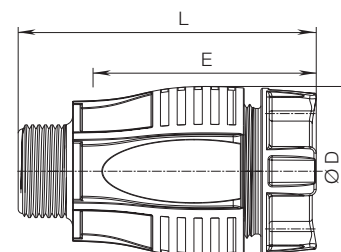

Design feature

- With internal thread according to ISO 228

Order No.	Ø Pipe	Thread	MOP (PN)	L	E	Ø D	Weight
6220HFA	25	¾"	16	93	74	54	0,10
	32	1"		102	80	61	0,14
	40	1¼"		117	81	75	0,23
	50	1½"		131	103	90	0,34
	63	2"		149	115	105	0,48

With internal thread No. 6220HFA

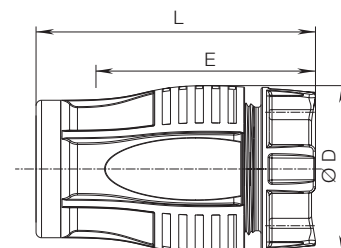

Order No.	Ø Pipe	MOP (PN)	L	E	Ø D	Weight
6320HFA	25	16	151	74	54	0,16
	32		163	80	61	0,22
	40		182	81	75	0,37
	50		208	103	90	0,54
	63		234	115	105	0,80

Connector No. 6320HFA

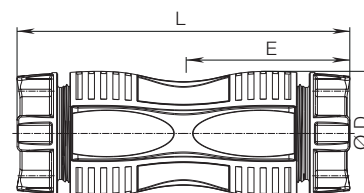

Hawle-Fit

Fittings for PE pipes

Order No.	ØPipe	MOP (PN)	L	E	ØD	Weight
6420HFA	25	16	94	74	54	0,18
	32		105	80	61	0,26
	40		121	81	75	0,43
	50		136	103	90	0,63
	63		159	115	105	0,91

Elbow 90°
No. 6420HFA

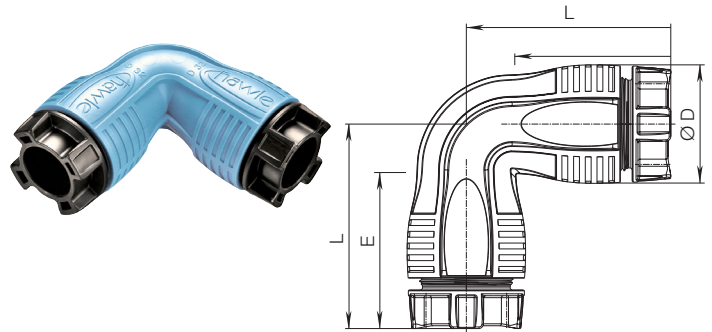

Design feature

- With internal thread according to ISO 228

Order No.	ØPipe	Thread	MOP (PN)	L	E	ØD	Weight
6430HFA	25	¾"	16	94	74	54	0,12
	32	1"		105	80	61	0,18
	40	1 ¼"		121	81	75	0,28
	50	1 ½"		137	103	90	0,44
	63	2"		159	115	105	0,62

Elbow 90° with internal thread
No. 6430HFA

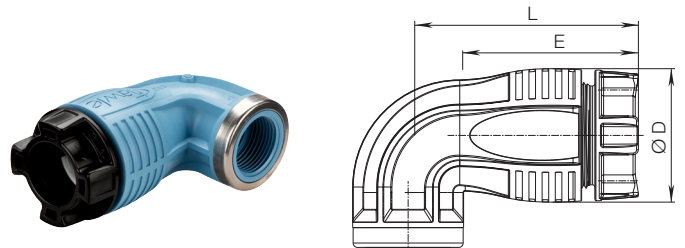

Design feature

- With internal thread according to ISO 228

Order No.	ØPipe	Thread	MOP (PN)	L	E	ØD	Weight
6520HFA	25	¾"	16	173	74	54	0,20
	32	1"		191	80	61	0,27
	40	1 ¼"		214	81	75	0,44
	50	1 ½"		240	103	90	0,65
	63	2"		291	115	105	0,99

T-piece with threaded outlet
No. 6520HFA

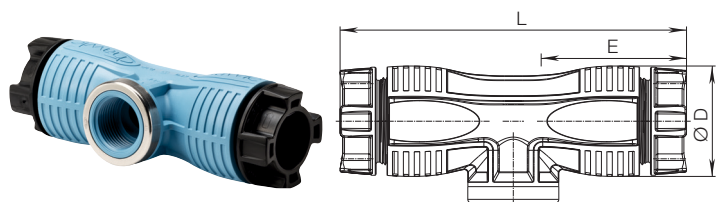

Order No.	ØPipe	MOP (PN)	L	E	ØD	Weight
6223HFA	25	16	99	82	62,5	0,25
	32		90	84	62,5	0,17
	40		113	105	73	0,28
	50		90	84	62,5	0,39
	63		132	125	103	0,57

End stop
No. 6223HFA

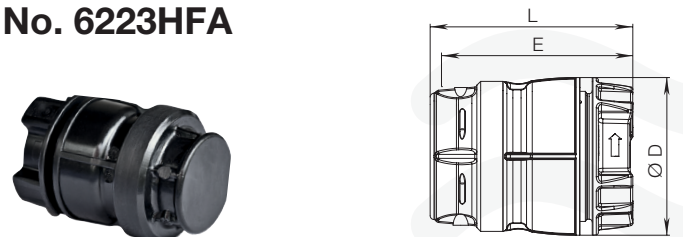

ZAK-Fittings

For PE pipes



Design features

- The threadless, restraint jointing system for the service connections made of ductile iron, epoxy powder coated
- Simple installation:
Push into socket- rotate for 90° - pull out - fit the snap ring



Order No.	MOP (PN)	Version	Pipe Ø d			
			32	40	50	63
6160	16	ZAK 46				
		ZAK 69				

Pipe Ø d		E	Weight
32	ZAK 46	70	0,70
40		84	0,80
50		101	1,20
63		114	1,60
50	ZAK 69	101	1,44
63		114	1,82

ZAK-ISO-adapter

No. 6160 made of ductile iron

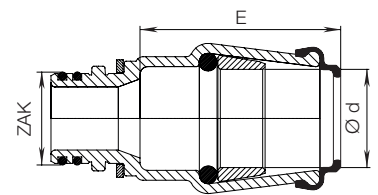

Design features

- Sanitation fitting with extended insertion
- Can be displaced, with cone part that can be dismantled

Order No.	MOP (PN)	Version	Pipe Ø d		
			40	50	63
6170	16	ZAK 46			

Pipe Ø d		L max.	L min.	Weight
32	ZAK 46	154	71	1,40
40		147	77	1,50
50		149	82	1,70
63		201	104	2,70

ZAK-fitting

No. 6170 Made of ductile iron

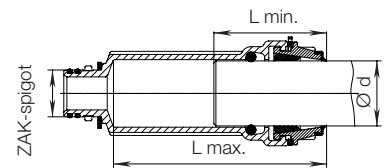

Design feature

- For fusion in PE-service valves with E-socket technology

Order No.	MOP (PN)	Version	Pipe Ø d			
			32	40	50	63
6180	16	ZAK 46				

Pipe Ø d		L	Weight
32	ZAK 46	200	0,60
40		200	0,60
50		220	0,90
63		230	1,20

ZAK-PE-tail

No. 6180 Made of ductile iron

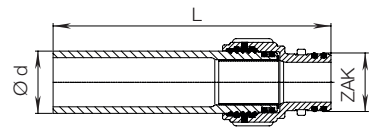

ZAK-Fittings

For PE pipes

Design feature

- 360° swivel type, ZAK-spigot, ISO socket

Order No.	MOP (PN)	Version	Pipe Ød				
			25	32	40	50	63
6465	16	ZAK 46					

Pipe Ød		L	E	Weight
25	ZAK 46	60	48	1,40
32		93	70	1,70
40		105	84	1,90
50		130	101	2,30
63		147	114	2,80

Design feature

- For fusion in PE-service valves with E-socket technology

Order No.	MOP (PN)	Version	Pipe Ød			
			32	40	50	63
6479	16	ZAK 46				

Pipe Ød		L	Weight
32	ZAK 46	69	1,00
40		78	0,65
50		89	0,85
63		110	1,30

Order No.	MOP (PN)	Version	Pipe Ød				
			25	32	40	50	63
6480	16	ZAK 46					

Pipe Ød		L	E	Weight
25	ZAK 46	71	58	0,72
32		87	70	0,96
40		104	84	1,20
50		141	101	1,65
63		163	114	2,10

Design feature

- With ZAK-sockets on all sides

Order No.	MOP (PN)	Version	L	H	Weight
6540	16	ZAK 46	120	60	1,10

ZAK-ISO elbow 90°

No. 6465 Made of ductile iron

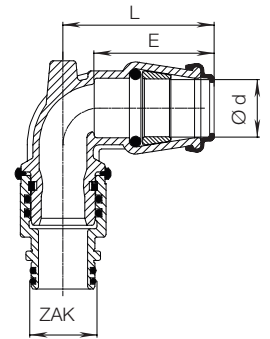

ZAK-elbow PE 90°

No. 6479 Made of ductile iron

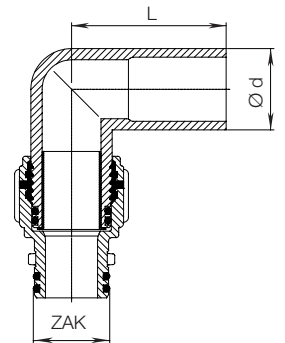

ZAK-ISO elbow 90°

No. 6480 Made of ductile iron

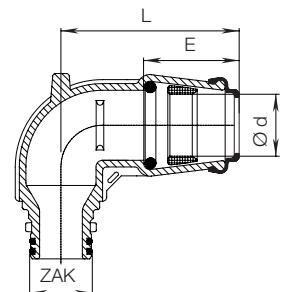

ZAK-Tee piece

No. 6540 Made of ductile iron

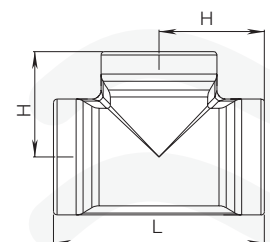

ISO pipe fitting

Fittings for PE pipes



Design features

- For PE pipes according to EN 12201-2 and DIN 8074, up to PN 16
- The Hawle ISO pipe fitting is the easiest way joining PE pipes
- The ISO pipe fitting is suitable for use in communal waste water area up to a temperature of 30 °C
- The gripping and sealing functions act only the o.d. of the pipe; therefore only one fitting is required for all pressure ratings up to PN 16
- The function of the ISO pipe fitting is clear and simple; the O-ring is made of elastomer and seals well even when the pressure is nil, because it is compressed onto the pipe
- As the water pressure and pipe tension increase, the sealing and grip rings are compressed further into the conical chamber, thus increasing the sealing and gripping effect
- The joint is flexible and the fitting can be turned on the pipe without affecting the grip or seal. Assembly the fitting is quick and simple and can be dismantled if required.
- This design has been well proven for many years in waste water distribution and is used in pipelines with pressures up to PN 16 (also in vacuum situations, with support liner)
- All ductile iron fittings with internal threads are fitted with a corrosion protection ring to prevent corrosion
- For ductile iron fittings with external thread, after assembly the free lying threads must be protected against corrosion according to the trade regulations

Material | Technical features

- **Body** made of ductile iron, epoxy powder coated
- **Grip ring** made of POM
- **O-ring gasket** made of elastomer

Suitable accessories

Chamfering tool:	No. 6000
Extractors:	No. 6010
Support liner:	No. 6021

Made of ductile iron

Epoxy powder-coated



All ISO pipe fittings can also be supplied for PVC pipes with a carborundum grip ring at extra cost.

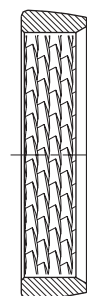

Grip ring
"Standard"
Interlocking
teeth



Grip ring
"carborundum"

Instruction

ISO pipe fitting instruction for assembly and dismantling

ASSEMBLY

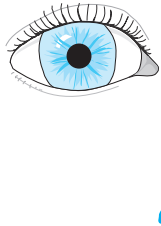
1 

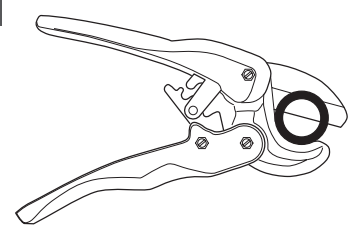
2 
Pipe cutter No. 6050

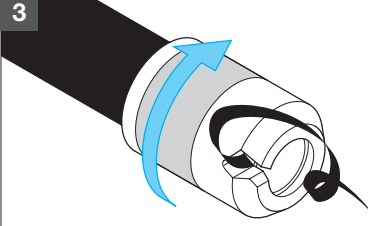
3 
Chamfering tool No. 6000

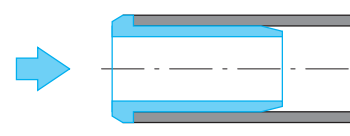
4 
Support liner No. 6021 for zero pressure and low pressure pipelines. Don't chamfer the pipe

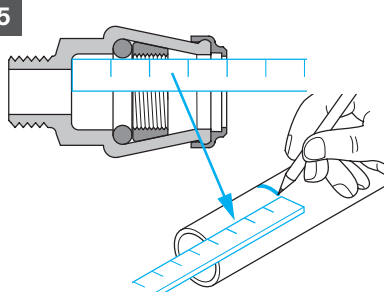
5 

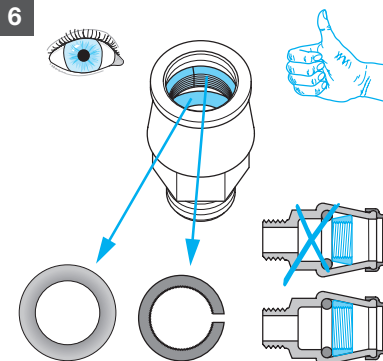
6 

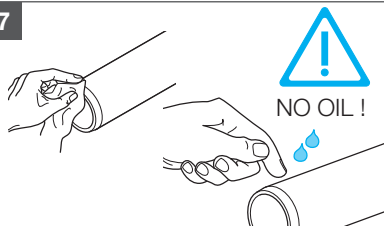
7 
Moisten with water or lubricants (see L 2/2)

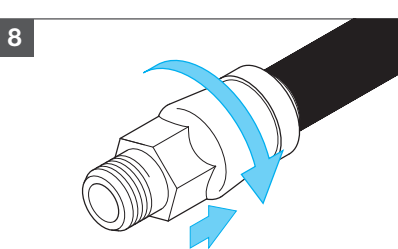
8 

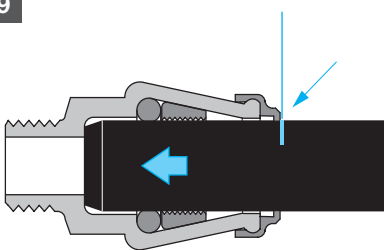
9 

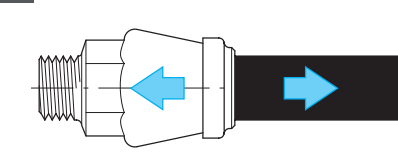
10 

11 **PRESSURE TEST** on installed line and exposed, unfilled connections

DISMANTLING

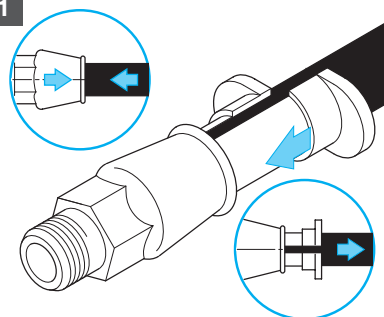
1 
Extractors No. 6010

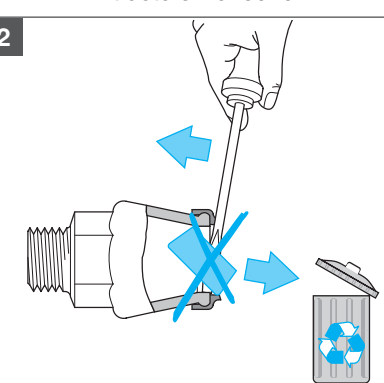
2 
Grip ring No. 6932 for PE pipes acc. to EN 12201-2
Grip ring No. 6931 for PVC pipes

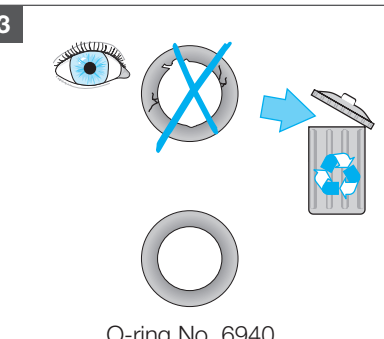
3 
O-ring No. 6940

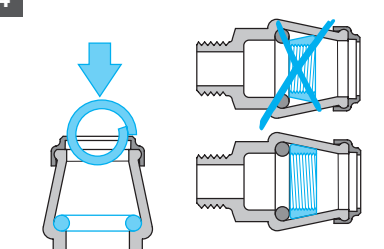
4 

5 **Assembly**

Max. torque for tightening the threads (observe pipe fitter rules acc. to national standards):

1/2"	3/4"	1"	1 1/4"	1 1/2"	2"
20 Nm	25 Nm	40 Nm	42 Nm	42 Nm	45 Nm

ISO Pipe Fittings

For PE pipes

Design feature

- With external thread according to EN 10226-1

Order No.	Ø Pipe	Thread	MOP (PN)	L	E	ØD	Weight
6100	32	1"	16	95	70	53	0,35
	40	1¼"		112	84	65	0,63
	50	1½"		130	101	76	0,90
	63	2"		148	114	94	1,45

Order No.	Ø Pipe	Thread	MOP (PN)	L	E	ØD	Weight
6110	32	1¼"	16	96	70	53	0,39
	32	1½"		96	70	53	0,60
	32	2"		112	70	62	0,63
	40	1"		112	84	65	0,65
	40	1½"		112	84	65	0,64
	40	2"		113	84	65	0,72
	50	1¼"		130	101	76	0,90
	50	2"		130	101	76	0,95
	63	1¼"		148	114	93	1,50
	63	1½"		148	114	93	1,45
	75	2"		152	109	111	2,41

Design feature

- With internal thread according to ISO 228

Order No.	Ø Pipe	Thread	MOP (PN)	L	E	ØD	Weight
6200	32	1"	16	91	70	55	0,42
	40	1¼"		108	84	65	0,70
	50	1½"		125	99	76	1,00
	63	2"		144	110	94	1,70
	75	2½"		144	110	110	3,20
	90	3"		144	110	126	3,60

Order No.	Ø Pipe	Thread	MOP (PN)	L	E	ØD	Weight
6210	32	1¼"	16	96	70	65	0,57
	50	1¼"		125	99	76	1,10
	90	2"		144	110	126	4,00

Order No.	Ø Pipe	MOP (PN)	L	E	ØD	Weight
6300	32	16	144	70	53	0,65
	40		172	84	65	0,97
	50		206	101	76	1,45
	63		232	114	94	2,70
	75		221	109	106	3,20
	90		195	109	126	4,70

External thread

No. 6100 Made of ductile iron

External thread, reduced outlet

No. 6110 Made of ductile iron

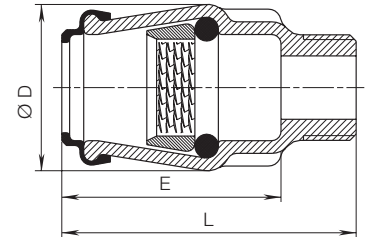

Internal thread

No. 6200 Made of ductile iron

Internal thread, reduced outlet

No. 6210 Made of ductile iron

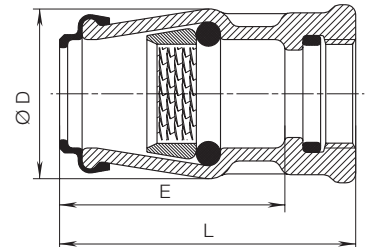

Connector

No. 6300 Made of ductile iron

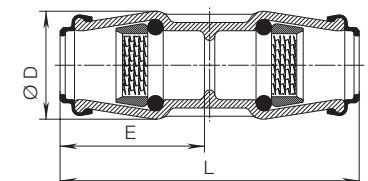

ISO Pipe Fittings

For PE pipes

Order No.	Ø Pipe	MOP (PN)	L	E	ØD	Weight
6301	32	16	172	86	70	1,10
	40		207	103	79	1,90
	50		216	108	90	2,10
	63		238	119	103	3,20

If using as sleeve - Attention: no stop

Connector With detachable ends for subsequent assembly

No. 6301 Made of ductile iron

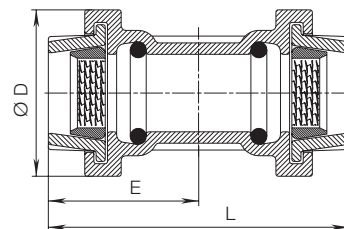

Order No.	Ø Pipe 1	Ø Pipe 2	MOP (PN)	L	E	E1	ØD	Weight
6310	40	32	16	160	84	70	72	0,80
	50	32		189	100	70	76	1,70
	50	40		191	100	84	76	1,20
	63	50		224	114	101	94	1,70
	75	63		221	109	103	106	3,70
	90	75		210	100	100	126	3,30

Connector reduced

No. 6310 Made of ductile iron

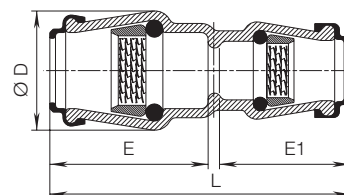

Order No.	Ø Pipe	MOP (PN)	L	E	ØD	Weight
6400	32	16	87	70	53	0,80
	40		104	84	65	1,20
	50		141	101	76	1,90
	63		163	114	94	3,15

Winkel 90°

No. 6400 Made of ductile iron

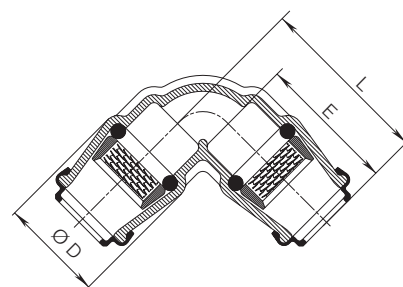

Order No.	Ø Pipe	MOP (PN)	L	E	ØD	Weight
6440	40	16	95	84	65	1,20
	50		108	101	76	1,89
	63		119	114	94	2,60
	90		132	110	126	5,11

Winkel 45°

No. 6440 Made of ductile iron

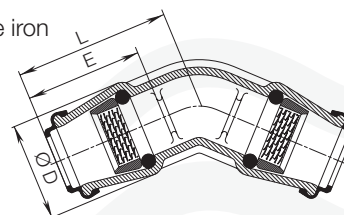

ISO Pipe Fittings

For PE pipes

Design feature

- With internal thread according to ISO 228

Order No.	Ø Pipe	Thread	MOP (PN)	L	E	ØD	Weight
6410	32	1"	16	87	70	53	0,70
	40	1¼"		106	84	65	1,17
	50	1½"		141	101	76	1,50
	63	2"		163	114	94	2,75

Elbow 90° With internal thread
No. 6410 Made of ductile iron

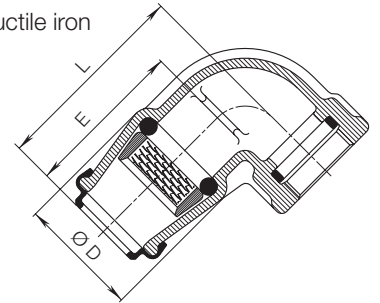

Design feature

- With external thread according to EN 10226-1

Order No.	Ø Pipe	Thread	MOP (PN)	L	E	ØD	Weight
6460	32	1"	16	87	70	53	0,56
	40	1¼"		104	84	65	1,10
	50	1½"		141	101	76	1,70
	63	2"		163	114	94	2,52

Elbow 90° With external thread
No. 6460 Made of ductile iron

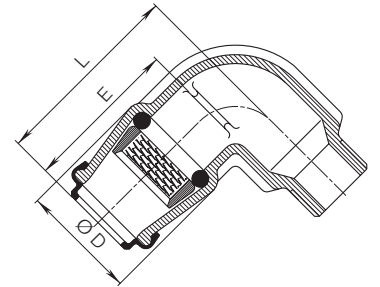

90° elbow with external thread reduced
No. 6470 Made of ductile iron

Order No.	Ø Pipe	Thread	MOP (PN)	L	E	ØD	Weight
6470	32	1¼"	16	90	70	53	0,60
	32	1½"		90	70	53	0,90
	32	2"		87	70	53	0,69
	40	1½"		141	101	76	1,10

Design feature

- With external thread according to EN 10226-1

Order No.	Ø Pipe	Thread	MOP (PN)	L	E	ØD	Weight
6411	32	1"	16	77	70	53	0,55
	32	2"		78	70	53	0,59

Elbow 45° With external thread
No. 6411 Made of ductile iron

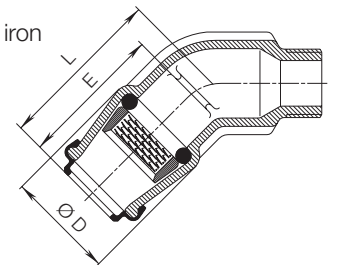

Design features

- With external thread according to EN 10226-1
- ISO socket 360° rotatable

Order No.	Ø Pipe	Thread	MOP (PN)	L	E	ØD	Weight
6462	63	1½"	16	148	105	93	2,65

Elbow 90° Swivelling fitting, with external thread
No. 6462 Made of ductile iron

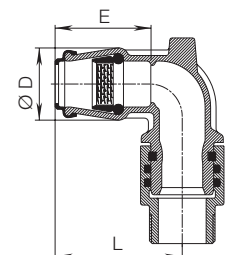

ISO Pipe Fittings

For PE pipes

Design feature

- With internal thread according to ISO 228

Order No.	Ø Pipe	Thread	MOP (PN)	L	E	Weight
6501	32	1"	16	195	80	1,50
	40	1¼"		228	93	2,40
	50	1½"		235	93	2,70
	63	2"		273	105	4,10

If using as sleeve - Attention: no stop

Design feature

- With internal thread according to ISO 228

Order No.	Ø Pipe	Thread	MOP (PN)	L	E	Weight
6500	32	1"	16	162	70	0,83
	40	1¼"		199	84	1,45
	50	1½"		239	101	2,20
	63	2"		245	114	3,90

Order No.	Ø Pipe	Thread	MOP (PN)	L	E	Weight
6510	50	2"	16	240	101	2,40
	75	1"		258	99	5,20
	75	2"		258	99	4,75

Order No.	Ø Pipe	MOP (PN)	L	E	Weight
6530	32	16	176	70	1,00
	40		214	84	2,20
	50		250	101	3,20
	63		300	114	4,80

Order No.	Ø Pipe 1	Ø Pipe 2	MOP (PN)	L	E	E1	Weight
6531	40	32	16	185	84	70	1,50
	50	25		218	101	58	2,00
	50	32		227	89	70	2,00
	50	40		240	89	84	2,60
	63	32		251	114	70	2,70
	63	40		262	114	84	3,20
	63	50		275	114	99	3,50

T-piece

With internal thread outlet, with detachable ends for subsequent assembly

No. 6501

Made of ductile iron

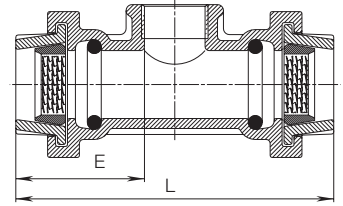

T-piece

With threaded outlet

No. 6500

Made of ductile iron

Internal thread reduced

No. 6510

Made of ductile iron

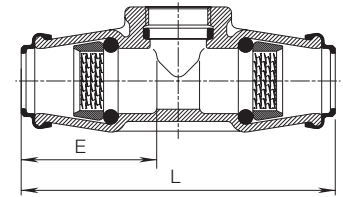

T-piece

With 3 sockets

No. 6530

Made of ductile iron

T-piece reduced

No. 6531

Made of ductile iron

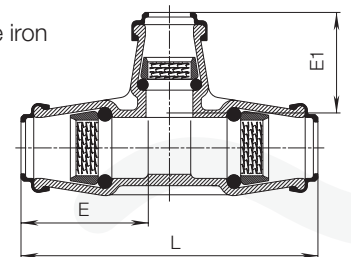

Tools

Drilling machine for drilling under pressure

Design features

- Can be used for drilling pipes of **steel, ductile iron, AC, PE** und **PVC**
- When drilling under pressure, swarf is washed out via an outlet
- Rotated by ratchet handle and fed by feed wing nut
- The ratchet is connected to the drill shaft with a simple locking device
- Pipe saddle adaptors and reducers are sealed with captivated rubber rings

Drilling machine

No. 5800



Content case		
Order No.	Description	Dimensions
5820	Drilling machine	
5810	Case	
5830	Ratchet	
5840	Shaft	
5850	Twist drill for steel, ductile iron and AC pipes	1" - Ø 24
		1¼" - Ø 29
		1½" - Ø 35
		2" - Ø 40
5860	Cup drill for PE and PVC-pipes	1" - Ø 24
		1¼" - Ø 29
		1½" - Ø 35
		2" - Ø 40
5890	Reducing adapter with rubber seals	2" - 1"
		2" - 1¼"
		2" - 1½"
5900	Equal adapter with rubber seals	2" - 2"
5910	1 pc. Allen key size 5	SW 5
5920	2 pc. C spanner for adapter	
8401	Saddle blade for shut-off	1" - 1¼"
		1½" - 2"
5800	Complete in case (weight 17,5 kg)	

Suitable accessories

- Cup drill for steel and ductil iron pipes: No. 5870
- Reducing adapter with rubber seals (2" — 2½"): No. 5890
- Adapter for ISO-combination tapping valve (2" — 1½"): No. 5940
- Adapter for thread-cutting machine REMS AMIGO 2: No. 5008555



No. 5860
Cup drill
For PE- and PVC-pipes



No. 5850
Twist drill
For steel, ductile iron and AC-pipes

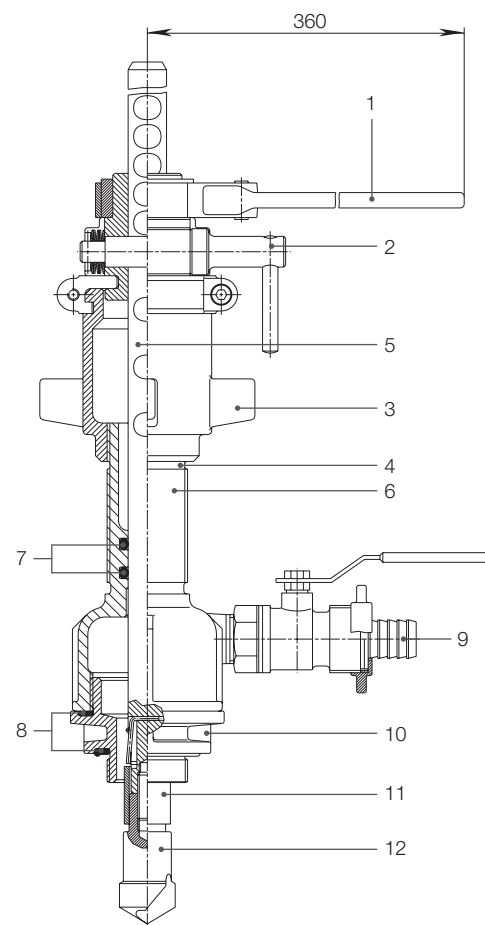

- | | | | |
|---|---------------------------|----|------------------------------------|
| 1 | Ratchet | 7 | O-ring |
| 2 | Shaft locking bolt | 8 | Rubber seal |
| 3 | Feed wing nut | 9 | Ball valve outlet (carrier) |
| 4 | Red marking | 10 | Adapter or reducer |
| 5 | Drill shaft | 11 | Hexagonal socket |
| 6 | Body | 12 | Twist drill |

Tools

Drilling machine Tonisco

Design features

- The Tonisco drilling machine is suitable for drilling up to $\varnothing 89$ pipelines made of **steel, ductile iron, AC, PE** and **PVC**
- Manual feed by means of a feed nut with a handwheel

		Content case		
Order No.	Description	Dimensions		
5807	Drilling machine			
	Case			
	Electrical drive*	220 V 50 Hz 1000 Watt		
	Ratchet			
	Shaft + extensions			
	Adapter for hole sawing			
	Hole saw	1" - $\varnothing 24$		
		1¼" - $\varnothing 30$		
		1½" - $\varnothing 38$		
		2" - $\varnothing 44$		
		DN 80 - $\varnothing 70$		
	Centre drill	DN 100 - $\varnothing 89$		
		$\varnothing 7$		
	Drill adapter with external thread	1"		
1¼"				
1½"				
2"				
Drill adapter with flange	DN 80			
	DN 100			

* Attention: 230 V - please observe safety regulations.

TONISCO-drilling machine

No. 5807



TONISCO-drilling machine No. 5807 can also be leased.

Thread adapter



Flange adapter



Hole saw



Centre drill



Design features

- Cut pipes square and straight
- The lever design minimises the force required

Order No.		for ØPipe	Weight	
6050	Type I:	up to 1¼" or Ø 40	0,30	
	Type II:	up to 2" or Ø 63	1,10	

Design features

- For easy assembly of ISO push-fit fittings the pipe should be beveled.
- We recommend our precision-made steel chamfering tool. This provides the correct chamfer when turned clockwise a few times on the pipe end

Order No.	ØPipe	DN	Weight	
6000	32	1"	0,10	
	40	1¼"	0,17	
	50	1½"	0,22	
	63	2"	0,62	

Design features

- For shut-off saddles and shut-off adaptors
- For under pressure drilling

Order No.		Size	Weight	
8401	Model I:	for saddle 1" — 1¼"	0,41	
	Model II:	for saddle 1½" — 2"	0,43	
		DN 80	0,50	

Design features

- First ensure that the grip ring is not under tension. When pushed in, the extractors separate the grip ring from the pipe, which can then be pulled out
- **Application:** for all Hawle products with ISO push-fit fittings

Order No.	Ø Pipe	DN	Qty. Extractors	Weight	
6010	32	1"	2	0,09	
	40	1¼"	2	0,14	
	50	1½"	2	0,19	
	63	2"	2	0,36	
	75		3	0,18	
	90		3	0,31	
	110		3	0,41	

Pipe cutter

Cuts PE- and PVC pipes

No. 6050



Symbol photo

Chamfering tool

For beveling PE pipes

No. 6000

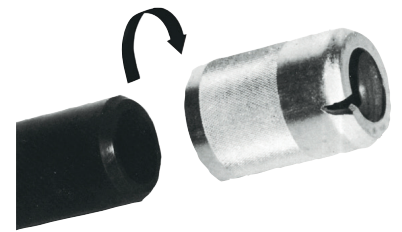

Saddle blade

No. 8401



Extractors

For dismantling ISO push-fit fittings

No. 6010

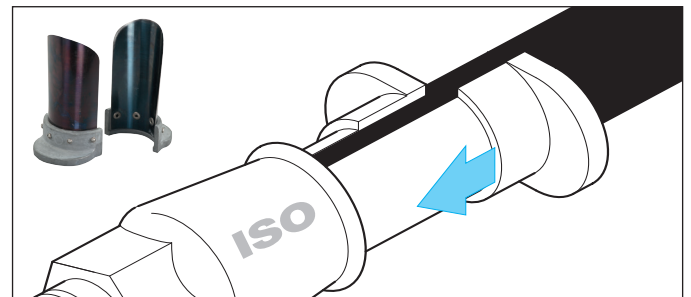

Tools

Order No.	Operating key for	Length	Weight	
3410	Service valves	850	1,90	
3420	Valves, extension spindles and below ground hydrants	1130	4,10	

Design features

- Drill set required for drilling of PE pipe in connection with HAKU saddles ZAK 69 and 45° outlet
- Suitable for drilling machine No. 5800 (K 1/1)

Material | Technical features

- 1 **Drill shaft adapter** made of stainless steel
- 2 **Drill bit** made of high speed steel (HSS)

Suitable accessories

Cup drill for PE / PVC

No. 5863

Design feature

- Special cup drill for drilling of PE and PVC pipes in connection with ZAK 69 drill set

Material | Technical features

- **Material:** HSS

Order No.	for Pipe Ø	Drill length	Drill Ø
5863	63 – 75	60	40
	90 – 225	70	50

Design feature

- For Hawle drilling machines No. 5800, No. 5805

Order No.	MOP (PN)	Version		Weight	
5895	16	IG 1"	ZAK 34	0,75	
		IG 1½"	ZAK 46	1,10	
		IG 2"		1,00	
		IG 2"	ZAK 69	2,20	

Operating key

No. 3410

No. 3420

Drill set ZAK 69

5008610

No. 5897

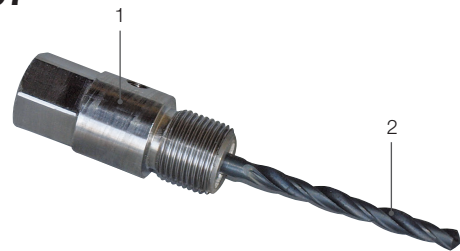

Cup drill ZAK 69

5008646 Ø 40

5008647 Ø 50

No. 5863



Illu.: drill set with assembled cup drill

ZAK adapter

No. 5895



Design feature

- Blue synthetic resin coating, UV-resistant

Order No.	Contents of can	
3441	1	

Design features

- For repair of minor mechanical damage caused by transport or installation.
- **Cartridge with plunger**
Exact 1:1 proportional dosing of resin and hardener. Good mixing is essential
- For repairing large areas we recommend No. 3441
- For potable water

Order No.	Cartridge content	
3442	32 cm ³	

Colour repairs

No. 3441

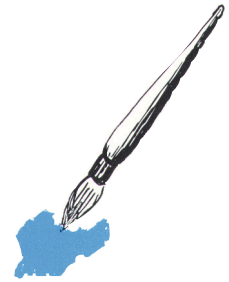

Repair cartridge

For powder coated Hawle products

No. 3442



Technical information

Sequence Of bolt assembly

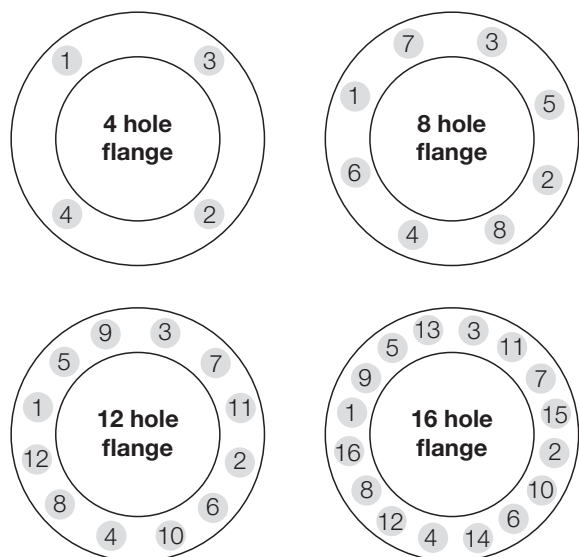

Tightening torques For flange assembly

Flange - flange PN 10

DN	Bolt dimensions	Tightening torque	
		Nm min.	Nm max.
50 – 125	M 16	80	100
150 – 350	M 20	100	120
400 – 500	M 24	140	160
600	M 27	200	220

Flange - flange PN 16

DN	Bolt dimensions	Tightening torque	
		Nm min.	Nm max.
50 – 125	M 16	80	100
150 – 200	M 20	100	120
300 – 350	M 24	140	160
400 – 450	M 27	200	220
500	M 30	260	280
600	M 33	330	350

Tightening torques HAKU shut-off saddle assembly

Ø Pipe	Bolt dimensions	Tightening torque	
		Nm min.	Nm max.
50 – 110	M 10	50	60
125 – 160	M 12	60	70
180 – 225	M 14	70	80
250 – 315	M 16	80	90
355 – 630	M 20	110	120

Tightening torques SYSTEM 2000 - lock ring

Ø Pipe	Bolt dimensions	Tightening torque	
		Nm min.	Nm max.
63 – 110	M 10	50	60
125 – 140	M 12	60	70
160 – 200	M 14	70	80
225 – 280	M 16	90	100
315 – 450	M 20	110	120
500 – 630	M 24	190	200

General information

- Spindle turns and guideline values for closing torques in delivered state of **HAWLE knife gate valve**
- Upper stop – lower stop

DN	Richtwerte										
	50	65	80	100	125	150	200	250	300	350	400
Stärke	50	65	80	100	125	150	200	250	300	350	400
Umschlag/Hub	13	17	8	10	13	15	20	21	25	29	34
Stückmoment [Nm] bei 10/6 bar (Wasser)	20	20	40	40	40	50	60	80	110	150	160
Spindel-Moment	10,3	10,3	14,8 19,3	14,8 19,3	19,3	19,3	19,3	24,3	24,3	27,3	27,3
Spindel- befestigung	M6	M6	M10	M10	M10	M10	M10	M12	M12	M16	M16

Spindle turns for Hawle knife gate valve

Pipe laying Equipment

Support liners for PE pipes

Class SDR 11 (PE 100 | PN 16)

Ø Pipe ext.	Ø D	Ø C	Ø A	F	E	B
32	25,2	19,3	31,5	62	6	26,5
40	31,6	25,3	39,5	72	7	33,2
50	39,6	32,7	49,5	82	7	41,5
63	50	42,1	62,5	91	8	52,2

Class SDR 17/17,6 (PE 100 | PN 10)

Ø Pipe ext.	Ø D	Ø C	Ø A	F	E	B
32	27,4	22,2	31,5	67	6	28,5
40	34,8	28,5	39,5	84	7	36
50	43,4	36,5	49,5	82	7	44,9
63	54,8	46,9	62,5	92	8	56,6

Support liners made of POM for PE pipes

No. 6021

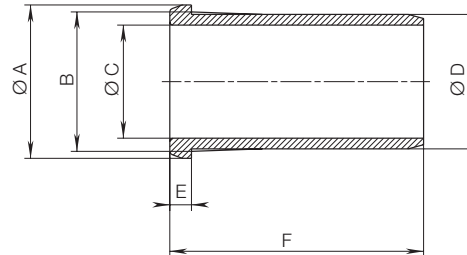

Ø Pipe ext.	L	Weight
63	170	0,10
75	170	0,25
90	170	0,33
110	170	0,39
125	170	0,48
140	170	0,55
160	200	0,67
180	220	0,86
200	220	1,50
225	220	1,62
250	220	1,85
280	220	2,15
315	220	2,55

Support liner made of stainless steel for PE pipes

No. 6035

Class SDR 17/17,6 (PE 100 | PN 10)

No. 6036

Class SDR 11 (PE 100 | PN 16)



DN	b		Weight	
	3470	3390	3470	3390
50	3	4	0,02	0,04
65	3	4	0,03	0,06
80	3	4	0,04	0,07
100	3	5	0,04	0,07
125	3	5	0,05	0,12
150	4	5	0,06	0,13
200	4	6	0,10	0,18
250	4	6	0,13	0,23
300	4	6	0,17	0,60
350		7		0,70
400		7		0,77

Flat gasket

No. 3470

- With fabric liner, PN 10
- Made of elastomer



No. 3470

Flat gasket

No. 3390

- Dimensionally stable reinforced steel, thus simpler to install
- Made of elastomer
- Standard version PN 10, PN 16 or PN 25 on request

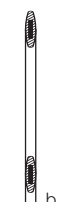

No. 3390

Pipe laying Equipment

Design features

For surface boxes according to:

- DIN 4056 (gate valves)
- DIN 4057 (service valves)
Safe fixture of Hawle telescopic extension spindles for gate valves, Combi-T and service valves
- Unbreakable and solid
- Easy assembly
- Low weight
- Durable, non-degradable

Order No.	Suitable for surface boxes acc. to	Weight	
3481	DIN 4056, DIN 4057	0,6	

Universal base plate No. 3481

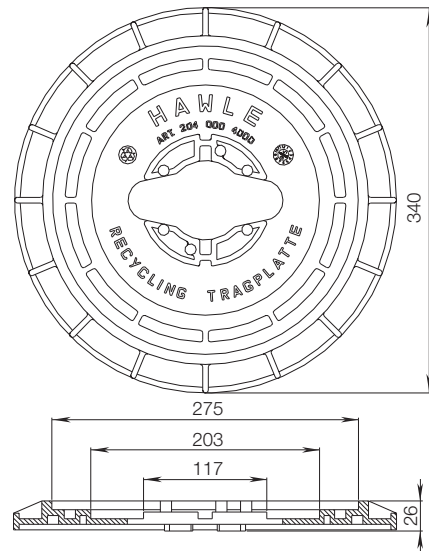
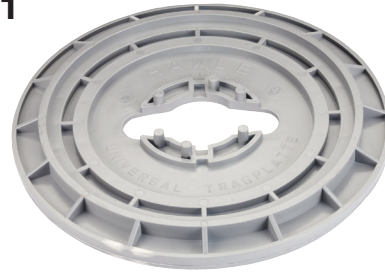

Design features

- Manhole cover and ring with opening for automatic air valve assembly, Order No. 9828
- Cover inscription „Abwasser“ and „Be- und Entlüftung“

Design features

- **Shaft cover** made of ductile iron, bituminised
- **Shaft ring** made of grey iron, bituminised

Manhole cover and ring for automatic air valve assembly No. 2069

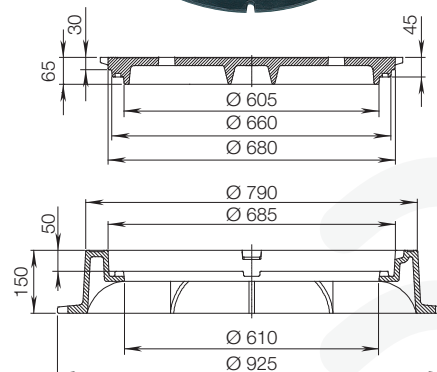

Pipe laying Equipment

For PVC pipes, PN 10 | PN 16



Design features

- The restraint clamp for PVC-U pipe fittings and pipes according to EN ISO 1452-2
- 1256: the restraint clamp for a Molecor PVC-O Tom® pipe PN 25 according to ISO 16422
- This two-part body can be assembled onto an existing pipeline. If required it can be dismantled and reused
- The grip ring is self tightening within its tapered seating
- The design of the teeth avoids cutting into the pipe resulting in the highest gripping force without pipe damage
- Wedge fastening on both sides
- Hammer the wedges until the clamp is tightly closed

Material | Technical features

- **Body** made of ductile iron, epoxy powder coated
- **Grip ring** made of brass
- **Wedge fastener** made of ductile iron, galvanised epoxy powder coated

Restraint clamp

No. 1254 / 1255 / 1256

(Socket - Pipe)



Grip ring
brass

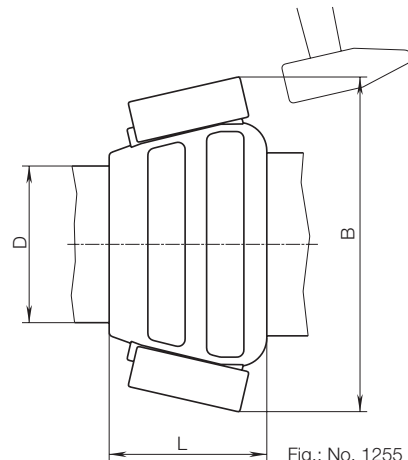

Fig.: No. 1255

Order No.	Version	MOP (PN)	Dimension/DN ØPVC-Pipe									
			50 63	65 75	80 90	100 110	125 140	150 160	200 225	250 280	300 315	
1254	Restraint clamp	10	+	+	+							
1255		16										

+ PN 10 and PN 16

PVC-O pipe PN 25

Application example



DN	Ø PVC-Rohr Ø PVC pipe	B		L		Weight Gewicht
		1254	1255	1254	1255	
50	63		180	91		2,5
65	75		200	96		2,8
80	90		220	103		3,0
100	110		240	110		3,5
125	140		280	123		3,9
150	160	300	320	140	152	6,0
200	225	380	400	165	185	9,5
250	280		455	195		13,5
300	315		495	200		16,3

** in preparation | # PVC-O pipe PN 25

Assembly Material

Design features

- For an easy installation
- Made of pure silicon (with a special solvent)
- Suitable for potable water
- Content: 400 ml
- **Attention:** observe the safety-instruction label on the can

Design features

- Suitable for valves, spindles and O-rings
- Content: 90 g

Mounting spray For PE and PVC pipes

No. 3443



Fitting grease

No. 3444



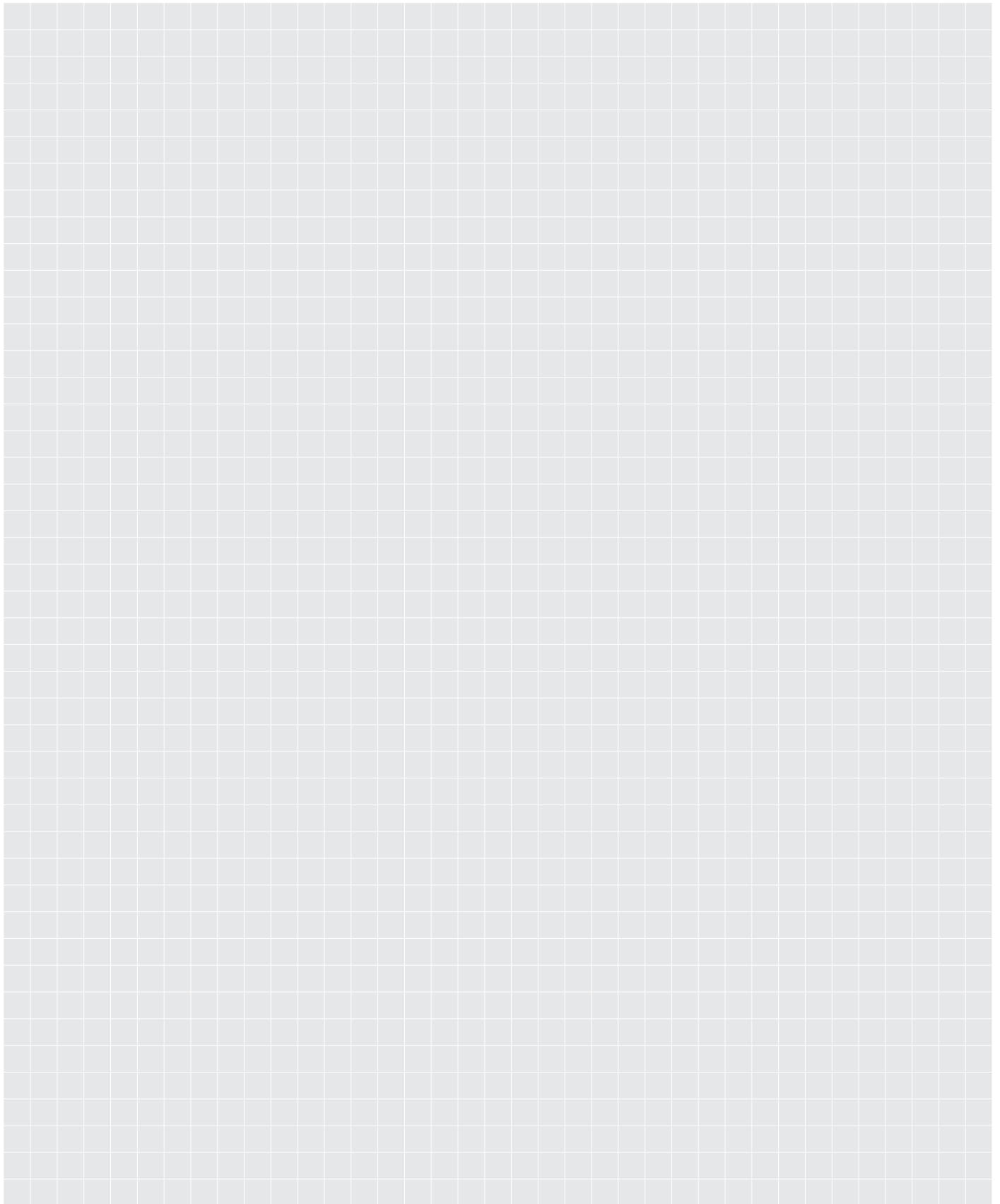

Conditions of Sale 2019

Last updated January 2019 / valid as of 01.01.2019

1 General

1.1 All offers, sales transactions, deliveries and other services provided by E. Hawle Armaturenwerke GmbH (henceforth referred to as „Hawle“) to our customers as of 01.01.2019 are subject exclusively to the following Conditions of Sale.

1.2 Hawle shall not recognise any conflicting or deviating terms and conditions of the customer unless Hawle has expressly agreed to their validity in writing.

1.3 Supplements and amendments to these Conditions of Sale as well as ancillary agreements must be made in writing in order to be effective. This also applies to the waiver of the written form requirement.

1.4 In the event that individual provisions of these Conditions of Sale are or become invalid, the remaining provisions shall remain effective. Ineffective provisions shall automatically be replaced by legally effective provisions which come as close as possible to the economic intent of the contracting parties.

1.5 It is the responsibility of the customer to assess the technical and legal suitability of the goods offered by Hawle for the use intended by the customer or his buyers. The customer is also required to observe export and import restrictions.

1.6 Any administrative authorisations required for the import of goods into their country of destination or for the use intended by the customer or his buyers must be obtained by the customer in good time. In the event that such authorisations are not obtained in good time, delivery dates and periods shall be extended accordingly.

1.7 Hawle reserves the property rights and copyrights to the product catalogue sheets, drawings, product photos, cost estimates and other documents prepared by Hawle. These documents may not be disclosed to third parties without the prior permission of Hawle.

2 Conclusion of contract

2.1 All offers and price lists issued by Hawle are subject to change and non-binding, unless expressly agreed otherwise, and only become binding once Hawle has confirmed the order in writing or performed an action set by Hawle in fulfilment of the contract (e.g. delivery/shipment of the goods).

2.2 Following the confirmation of the order or the performance of an action in fulfilment of the contract by Hawle, the customer may withdraw from the contract only with the prior written consent of Hawle. Unilateral withdrawal from the contract on the part of the customer is not permitted.

3 Prices and terms of payment

3.1 All documents pertaining to an offer such as drawings, illustrations and weight specifications shall only be regarded as approximate unless they are expressly designated as being binding. This reservation applies in particular to obvious errors, typographical errors, printing errors and miscalculations.

3.2 Unless otherwise agreed, the prices quoted by Hawle are in EURO Ex Works Frankenmarkt (EXW, Incoterms 2010), excluding in particular packaging, transport costs, transport insurance, sales tax and export and import duties. Packaging, loading, transport costs and transport insurance as well as potential taxes and duties shall be invoiced separately by Hawle.

3.3 Any changes in wage costs due to collective or statutory regulations

or internal agreements as well as changes in other costs relevant to the calculation of costs necessary for the provision of the service, such as the costs incurred for materials, energy, transport, third-party work, financing, etc., shall entitle Hawle to increase the prices accordingly. For this reason, the customer shall have neither the right to withdraw from the contract nor the right to assert that the basis of the transaction has ceased to exist. Orders confirmed by Hawle are exempt from potential price changes.

3.4 Unless otherwise agreed, net payment must be made by the customer within 30 days from the date of invoice. Payments will be offset against the oldest claim due in each respective case.

3.5 The possibility of offsetting payments against claims made by Hawle is excluded.

3.6 In the event that the customer defaults on payment, Hawle shall be released from all further service and delivery obligations and be entitled to withhold any outstanding deliveries or services or to demand advance payments or guarantees.

3.7 In the event that, upon conclusion of the contract, a significant deterioration in the financial circumstances of the customer occurs, or if circumstances become known which from Hawle's point of view are likely to reduce the creditworthiness of the customer, Hawle shall have the right to change due dates for outstanding claims, withhold deliveries to the customer and adjust conditions for future legal transactions with immediate effect.

4 Delivery

4.1 Orders confirmed by Hawle shall be fulfilled by Hawle as swiftly and diligently as possible. The delivery dates and periods announced by Hawle are merely intended to serve as a guideline and are always non-binding unless the stated delivery dates and periods have been expressly designated as binding by Hawle.

4.2 In the event of force majeure or any unforeseeable obstacle for which Hawle is not responsible, delivery dates and deadlines shall be reasonably extended by the duration of the impediment. This shall also apply if Hawle's sub-suppliers encounter such impediments. These include, in particular, official measures, strikes and lock-outs, natural disasters, market-related problems with material procurement as well as import and export restrictions.

4.3 Hawle deliveries may always be divided into sub-deliveries. Hawle is at liberty to make partial deliveries or provide partial services and to issue partial invoices to the customer.

4.4 National and international goods traffic is subject to the terms of delivery FCA, 4890 Frankenmarkt, Hawle dispatch warehouse (Incoterms 2010), unless another delivery clause has been explicitly agreed.

4.5 In the case of a sales shipment, the transfer of risk takes place once the purchased item has been handed over to the first carrier. Where acceptance of a service is required, Hawle's notification of readiness for acceptance shall be decisive for the transfer of risk.

4.6 The customer is obliged to accept the deliveries and services provided by Hawle as per contract. In the event of default of acceptance or a culpable breach of other obligations to cooperate on the part of the customer, Hawle is entitled to demand compensation from the customer for any damage incurred as a result, including any additional expenses.

Conditions of Sale 2019

Last updated January 2019 / valid as of 01.01.2019



4.7 Hawle is entitled to make changes to the technical design of the goods ordered, provided that these do not result in significant functional changes and the customer does not demonstrate the unreasonable nature of such changes. Unreasonableness is to be ruled out if the change constitutes a technical improvement or is caused by the further development of the state of the art or by legal or official measures.

4.8 In principle, the customer is not entitled to refunds or replacements. Refunds and replacements are only possible in exceptional cases and require the prior written consent of Hawle.

4.9 The goods delivered by Hawle to the customer are intended for use or resale in the customer's country of residence or in the country of the place of delivery.

5 Reservation of title

5.1 All goods delivered by Hawle remain the property of Hawle until payment has been made in full.

5.2 The customer is authorised to resell the goods in the regular course of business, even during the period in which the goods are subject to reservation of title. If, however, the customer is in default of payment to Hawle, Hawle may prohibit the resale of the goods subject to reservation of title.

5.3 The customer herewith cedes to Hawle all purchase price claims, including all ancillary rights, arising from a resale of the goods to his customers. Hawle accepts this assignment. These purchase price claims serve as security for the goods subject to retention of title.

6 Warranty

6.1 The customer must inspect the received goods with respect to quantity and quality immediately upon receipt. Written notices of defects must be submitted by the customer immediately after receipt of the delivery, but at the latest within 10 days from the date of delivery and prior to any handling or processing, otherwise excluding any warranty claims and/or claims for damages and/or avoidance on account of mistake, but do not entitle the customer to retain the invoiced amounts or portions thereof.

6.2 The warranty period for defects which were not detected during the inspection of the shipment is six months from the date of delivery and is neither extended nor interrupted by attempts at improvement; it also applies to partial deliveries. Notification of any such defects must be given in writing within 10 days from the date the defect was discovered, otherwise excluding warranty claims and/or claims for damages and/or avoidance on account of mistake, but do not entitle the customer to retain the invoiced amounts or portions thereof.

6.3 It has been agreed between Hawle and the customer that a hydrostatic pressure test in accordance with EN 805 is to be performed after laying a pipeline but prior to the main backfilling of the pipe trench or further constructional measures in shafts, plants or buildings which restrict accessibility to the valves and pipe fittings. If such a test is not performed, the customer or his customers shall be charged with contributory negligence of at least 50% in the event of damage. The customer agrees to inform his customers accordingly and to pass on this obligation to perform the described hydrostatic pressure test to his customers.

6.4 Possible warranty obligations generally cover the defective goods, but not the expenses otherwise associated with correcting the defect such as excavation costs, working hours and travel expenses.

6.5 The customer always bears the burden of proving that the delivered goods were defective at the time of delivery.

6.6 The place of performance for warranty obligations is always the place of delivery agreed for the original delivery.

6.7 Hawle shall be free to decide whether to fulfil possible warranty claims by means of replacements, improvement measures, price reductions or conversions.

7 Damages and liability

7.1 Any consulting provided by Hawle, whether verbal or in writing, is non-binding and does not release the customer from his obligation to examine the goods with respect to their suitability and the intended purpose. This applies above all, but not exclusively, to the suitability of the goods for the use intended by the customer or his customers, in particular to their suitability for the substances (gases and/or liquids) to be conveyed.

7.2 Hawle shall be liable for damages caused to the customer in the course of processing the business transaction in an amount not exceeding the value of the order placed with Hawle, and only in the event of gross negligence on the part of Hawle or gross negligence on the part of the executors working for Hawle, with the exception of personal injuries in which case Hawle shall be liable even in the event of minor negligence. The burden of proving gross negligence always lies with the injured party.

7.3 IN NO EVENT SHALL Hawle BE HELD LIABLE, WHETHER IN TORT OR CONTRACT, FOR INDIRECT DAMAGES, CONSEQUENTIAL DAMAGES, PURELY PECUNIARY LOSSES, FOREGONE PROFITS OR DAMAGES ARISING FROM DELAYS OR OUT OF THIRD PARTY CLAIMS.

7.4 The time limit for asserting claims for damages is one year from the date on which the customer gains knowledge of, or is subject to, negligent ignorance of the damage and the injuring party.

7.5 In the event that the customer himself is held liable under product liability law, he undertakes to immediately notify Hawle thereof by telephone or in writing and to immediately inform Hawle of the address of the claimant, failing which the customer's right of recourse against Hawle arising from product liability will cease to apply. Negotiations of claims arising from product liability with respect to Hawle products shall be conducted exclusively by Hawle.

8 Place of performance, court of jurisdiction, applicable law

8.1 The place of performance for both delivery and payment is always 4840 Vöcklabruck/Austria, even if a different place of delivery has been agreed individually.

8.2 The exclusive court of jurisdiction for all disputes arising from legal transactions between the customer and Hawle is the competent court in 4840 Vöcklabruck/Austria. Moreover, Hawle is also entitled to sue at the customer's registered office.

8.3 All legal transactions between the customer and Hawle are subject exclusively to Austrian substantive law, excluding international conflict of law rules. The application of the UN Convention on Contracts for the International Sale of Goods (CISG) is explicitly excluded.



E. Hawle Armaturenwerke GmbH

Wagrainer Straße 13 | 4840 Vöcklabruck | Austria

☎ +43 7672 72 576-0

📠 +43 7672 78 464

✉ hawle@hawle.at

hawle.com



PEFC® Printed on recycled, chlorine-free bleached paper and aging.

Art.-Nr.: HAW-402-EN